

THS7530 高速全差分连续 可变增益放大器

1 特性

- 低噪声： $V_n = 1.1\text{nV}/\sqrt{\text{Hz}}$ ，噪声系数 = 9dB
- 低失真：
 - 频率为 32MHz 时： $\text{HD}_2 = -65\text{dBc}$ ， $\text{HD}_3 = -61\text{dBc}$
 - 频率为 70MHz 时： $\text{IMD}_3 = -62\text{dBc}$ ， $\text{OIP}_3 = 21\text{dBm}$
- 300MHz 带宽
- 连续可变增益范围：11.6dB 至 46.5dB
- 增益斜坡：38.8dB/V
- 全差分输入和输出
- 输出共模电压控制
- 输出电压限制

2 应用

- 超声波应用、声纳和雷达中的时间增益放大器
- 通信和视频中的自动增益控制
- 通信中的系统增益校准
- 仪表中的可变增益

3 说明

THS7530 器件采用德州仪器 (TI) 先进的 BiCom III SiGe 互补双极工艺制造。THS7530 是一款带有压控增益的直流耦合高带宽放大器。该放大器具有高阻抗差分输入和低阻抗差分输出，提供高带宽增益控制、输出共模控制和输出电压钳位功能。

带宽为 300MHz 时信号通道性能卓越，而带宽为 32MHz 且 $1V_{PP}$ 输出到 400Ω 时会出现 -61dBc 的三次谐波失真。

增益控制 (单位：dB) 呈线性变化。在 0V 至 0.9V 电压范围内，增益以 38.8dB/V 的斜率由 11.6dB 变化为 46.5dB。

输出电压限制功能用于限制输出电压摆幅并避免后续级发生饱和。

该器件可在工业级温度范围内 (-40°C 至 $+85^\circ\text{C}$) 额定运行。

器件信息(1)

器件型号	封装	封装尺寸 (标称值)
THS7530	HTSSOP (14)	5.00mm × 4.40mm

(1) 如需了解所有可用封装，请参阅数据表末尾的可订购产品附录。

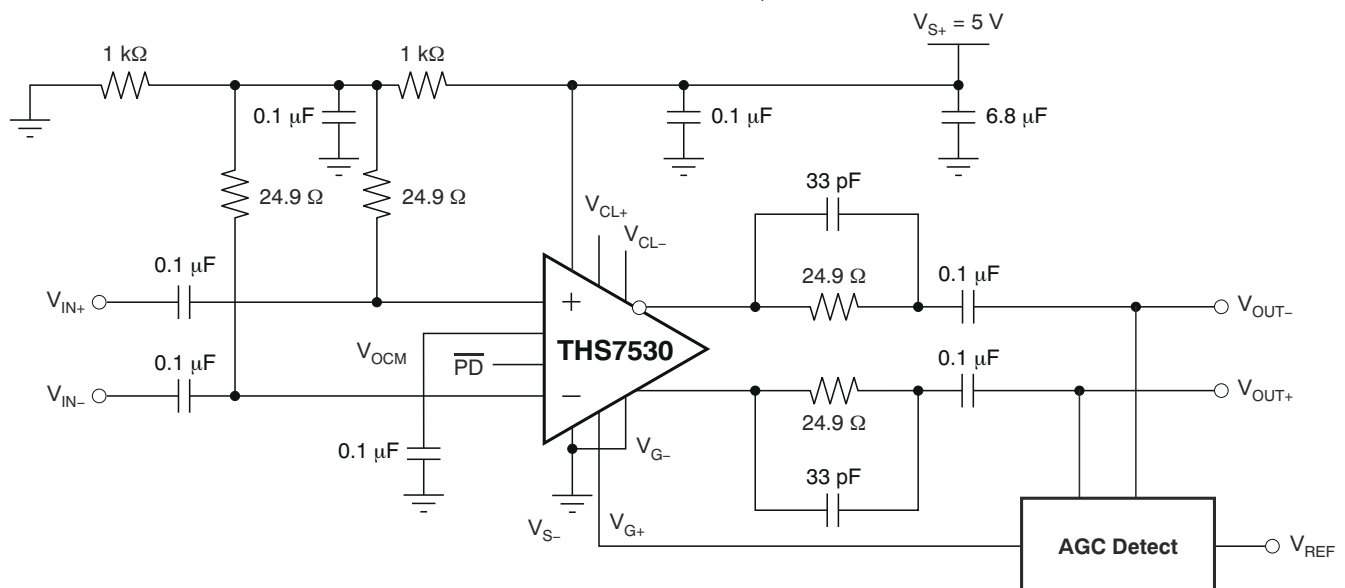

典型应用电路



Table of Contents

1 特性	1	8.3 Feature Description.....	12
2 应用	1	8.4 Device Functional Modes.....	13
3 说明	1	9 Application and Implementation	14
4 Revision History	2	9.1 Application Information.....	14
5 Pin Configuration and Functions	3	9.2 Typical Application.....	16
Pin Functions.....	3	10 Power Supply Recommendations	18
6 Specifications	4	11 Layout	19
6.1 Absolute Maximum Ratings.....	4	11.1 Layout Guidelines.....	19
6.2 ESD Ratings.....	4	11.2 Layout Examples.....	21
6.3 Recommended Operating Conditions.....	4	12 Device and Documentation Support	23
6.4 Thermal Information.....	4	12.1 Device Support.....	23
6.5 Electrical Characteristics: Main Amplifier.....	5	12.2 Documentation Support.....	23
6.6 Package Thermal Data.....	7	12.3 支持资源.....	23
6.7 Typical Characteristics.....	7	12.4 Trademarks.....	23
7 Parameter Measurement Information	10	12.5 静电放电警告.....	23
7.1 Test Circuits.....	10	12.6 术语表.....	23
8 Detailed Description	12	13 Mechanical, Packaging, and Orderable Information	23
8.1 Overview.....	12		
8.2 Functional Block Diagram.....	12		

4 Revision History

注：以前版本的页码可能与当前版本的页码不同

Changes from Revision D (July 2015) to Revision E (August 2020)	Page
• 更新了整个文档中的表格、图和交叉参考的编号格式.....	1

Changes from Revision C (February 2010) to Revision D (July 2015)	Page
• 添加了 ESD 等级表、特性说明部分、器件功能模式、应用和实施部分、电源相关建议部分、布局部分、器件和文档支持部分以及机械、封装和可订购信息部分.....	1

Changes from Revision B (February 2006) to Revision C (February 2010)	Page
• 更正了首页图片中的输入和输出极性指示.....	1
• Deleted <i>lead temperature</i> specification from Absolute Maximum Ratings table.....	4
• Corrected 图 7-2	10
• Changed 图 9-2 and 图 9-3 to correct problem with output polarity indication.....	14
• Changed 图 9-4 and 图 9-5 to correct problem with output polarity indication.....	14

5 Pin Configuration and Functions



图 5-1. PWP Package 14-Pin HTSSOP With PowerPAD™ Top View

Pin Functions

PIN		I/O	DESCRIPTION
NAME	NO.		
NC	1	—	No internal connection
	2		
PD	7	—	Power down, \overline{PD} = logic low puts the device into low power mode; \overline{PD} = logic high or open for normal operation
V_{CL-}	13	I	Output negative clamp voltage input
V_{CL+}	14	I	Output positive clamp voltage input
V_{G-}	6	I	Gain setting negative input
V_{G+}	5	I	Gain setting positive input
V_{IN-}	4	I	Inverting amplifier input
V_{IN+}	3	I	Noninverting amplifier input
V_{OCM}	12	I	Output common-mode voltage input
V_{OUT-}	11	O	Inverted amplifier output
V_{OUT+}	10	O	Noninverted amplifier output
V_{S-}	8	I	Negative amplifier power-supply input
V_{S+}	9	I	Positive amplifier power-supply input

6 Specifications

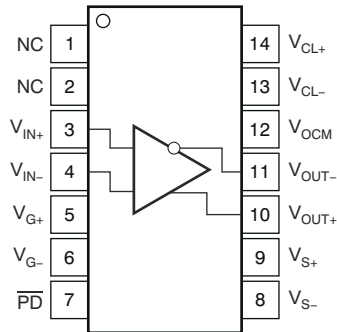
6.1 Absolute Maximum Ratings

Over operating free-air temperature range, unless otherwise noted.⁽¹⁾

		MIN	MAX	UNIT
$V_{S+} - V_{S-}$	Supply voltage		5.5	V
V_I	Input voltage		$\pm V_S$	V
I_O	Output current		65	mA
V_{ID}	Differential input voltage		± 4	V
	Continuous power dissipation	See # 6.4		
T_J	Maximum junction temperature		150	$^{\circ}\text{C}$
	Maximum junction temperature for long term stability ⁽²⁾		125	$^{\circ}\text{C}$
T_{stg}	Storage temperature	- 65	150	$^{\circ}\text{C}$

- Stresses beyond those listed under *Absolute Maximum Ratings* may cause permanent damage to the device. These are stress ratings only, which do not imply functional operation of the device at these or any other conditions beyond those indicated under *Recommended Operating Conditions*. Exposure to absolute-maximum-rated conditions for extended periods may affect device reliability.
- The maximum junction temperature for continuous operation is limited by package constraints. Operation above this temperature may result in reduced reliability and/or lifetime of the device.

6.2 ESD Ratings

		VALUE	UNIT
$V_{(ESD)}$	Electrostatic discharge		
	Human body model (HBM), per ANSI/ESDA/JEDEC JS-001 ⁽¹⁾	± 3000	V
	Charged device model (CDM), per JEDEC specification JESD22-C101 ⁽²⁾	± 1500	
Machine model (MM)	± 200		

- JEDEC document JEP155 states that 500-V HBM allows safe manufacturing with a standard ESD control process.
- JEDEC document JEP157 states that 250-V CDM allows safe manufacturing with a standard ESD control process.

6.3 Recommended Operating Conditions

		MIN	NOM	MAX	UNIT
$[V_{S-} \text{ to } V_{S+}]$	Supply voltage	4.5	5	5.5	V
	Input common mode voltage	$[V_{S-} \text{ to } V_{S+}] = 5 \text{ V}$		2.5	V
	Output common mode voltage	$[V_{S-} \text{ to } V_{S+}] = 5 \text{ V}$		2.5	V
T_A	Operating free-air temperature	- 40		85	$^{\circ}\text{C}$

6.4 Thermal Information

THERMAL METRIC ⁽¹⁾		THS7530	
		PWP (HTSSOP)	UNIT
		14 PINS	
$R_{\theta JA}$	Junction-to-ambient thermal resistance	50.4	$^{\circ}\text{C}/\text{W}$
$R_{\theta JC(\text{top})}$	Junction-to-case (top) thermal resistance	34.9	$^{\circ}\text{C}/\text{W}$
$R_{\theta JB}$	Junction-to-board thermal resistance	29	$^{\circ}\text{C}/\text{W}$
ψ_{JT}	Junction-to-top characterization parameter	1.6	$^{\circ}\text{C}/\text{W}$
ψ_{JB}	Junction-to-board characterization parameter	28.7	$^{\circ}\text{C}/\text{W}$
$R_{\theta JC(\text{bot})}$	Junction-to-case (bottom) thermal resistance	3.2	$^{\circ}\text{C}/\text{W}$

- For more information about traditional and new thermal metrics, see the *Semiconductor and IC Package Thermal Metrics* application report, [SPRA953](#).

6.5 Electrical Characteristics: Main Amplifier

$V_{S+} = 5\text{ V}$, $V_{S-} = 0\text{ V}$, $V_{OCM} = 2.5\text{ V}$, $V_{ICM} = 2.5\text{ V}$, $V_{G-} = 0\text{ V}$, $V_{G+} = 1\text{ V}$ (maximum gain), $T_A = 25^\circ\text{C}$, AC performance measured using the AC test circuit shown in [Figure 7-1](#) (unless otherwise noted). DC performance is measured using the DC test circuit shown in [Figure 7-2](#) (unless otherwise noted)

PARAMETER	TEST CONDITIONS	MIN	TYP	MAX	UNIT
AC PERFORMANCE					
Small-signal bandwidth	All gains, $P_{IN} = -45\text{ dBm}$		300		MHz
Slew rate ⁽¹⁾	1- V_{PP} Step, 25% to 75%, minimum gain		1250		V/ μs
Settling time to 1% ⁽¹⁾	1- V_{PP} Step, minimum gain		11		ns
Harmonic distortion, 2nd harmonic	$f = 32\text{ MHz}$, $V_{O(PP)} = 1\text{ V}$, $R_{L(diff)} = 400\ \Omega$		-65		dBc
Harmonic distortion, 3rd harmonic	$f = 32\text{ MHz}$, $V_{O(PP)} = 1\text{ V}$, $R_{L(diff)} = 400\ \Omega$		-61		dBc
Third-order intermodulation distortion	$P_O = -10\text{ dBm}$ each tone, $f_C = 70\text{ MHz}$, 200-kHz tone spacing		-62		dBc
Third-order output intercept point	$f_C = 70\text{ MHz}$, 200-kHz tone spacing		21		dBm
Noise figure (with input termination)	Source impedance: $50\ \Omega$		9		dB
Total input voltage noise	$f > 100\text{ kHz}$		1.1		nV/ $\sqrt{\text{Hz}}$
DC PERFORMANCE—INPUTS					
Input bias current	$T_A = 25^\circ\text{C}$		20	39	μA
	$T_A = -40^\circ\text{C}$ to $+85^\circ\text{C}$			40	
Input bias current offset			<150		pA
Minimum input voltage	Minimum gain, $T_A = 25^\circ\text{C}$		1.5	1.6	V
	Minimum gain, $T_A = -40^\circ\text{C}$ to $+85^\circ\text{C}$			1.7	
Maximum input voltage	Minimum gain, $T_A = 25^\circ\text{C}$	3.35	3.5		V
	Minimum gain, $T_A = -40^\circ\text{C}$ to $+85^\circ\text{C}$	3.2			
Common-mode rejection ratio	$T_A = 25^\circ\text{C}$	56	114		dB
	$T_A = -40^\circ\text{C}$ to $+85^\circ\text{C}$	44			
Differential input impedance			8.5 3		k Ω pF
DC PERFORMANCE—OUTPUTS					
Output offset voltage	All gains, $T_A = 25^\circ\text{C}$		± 100	± 340	mV
	All gains, $T_A = -40^\circ\text{C}$ to $+85^\circ\text{C}$			± 480	
Maximum output voltage high	$T_A = 25^\circ\text{C}$	3.275	3.5		V
	$T_A = -40^\circ\text{C}$ to $+85^\circ\text{C}$	3.25			
Minimum output voltage low	$T_A = 25^\circ\text{C}$		1.5	1.7	V
	$T_A = -40^\circ\text{C}$ to $+85^\circ\text{C}$			1.8	
Output current	$T_A = 25^\circ\text{C}$	± 16	± 37		mA
	$T_A = -40^\circ\text{C}$ to $+85^\circ\text{C}$	± 16			
Output impedance			15		Ω
OUTPUT COMMON-MODE VOLTAGE CONTROL					
Small-signal bandwidth			32		MHz
Gain			1		V/V
Common-mode offset voltage	$T_A = 25^\circ\text{C}$		4.5	12	mV
	$T_A = -40^\circ\text{C}$ to $+85^\circ\text{C}$			13.8	
Minimum input voltage			1.75		V
Maximum input voltage			3.25		V
Input impedance			25 1		k Ω pF
Default voltage, with no connect			2.5		V
Input bias current			<1		μA
GAIN CONTROL					
Gain control differential voltage range	V_{G+}		0 to 1		V
Minus gain control voltage	$V_{G-} - V_{S-}$		-0.6 to 0.8		V

6.5 Electrical Characteristics: Main Amplifier (continued)

$V_{S+} = 5\text{ V}$, $V_{S-} = 0\text{ V}$, $V_{OCM} = 2.5\text{ V}$, $V_{ICM} = 2.5\text{ V}$, $V_{G-} = 0\text{ V}$, $V_{G+} = 1\text{ V}$ (maximum gain), $T_A = 25^\circ\text{C}$, AC performance measured using the AC test circuit shown in [Figure 7-1](#) (unless otherwise noted). DC performance is measured using the DC test circuit shown in [Figure 7-2](#) (unless otherwise noted)

PARAMETER	TEST CONDITIONS	MIN	TYP	MAX	UNIT
Minimum gain	$V_{G+} = 0\text{ V}$		11.6		dB
Maximum gain	$V_{G+} = 0.9\text{ V}$		46.5		dB
Gain slope	$V_{G+} = 0\text{ V}$ to 0.9 V		38.8		dB/V
Gain slope variation	$V_{G+} = 0\text{ V}$ to 0.9 V		± 1.5		dB/V
Gain error	$V_{G+} = 0\text{ V}$ to 0.15 V		± 4		dB
	$V_{G+} = 0.15\text{ V}$ to 0.9 V		± 2.25		
Gain control input bias current			<1		μA
Gain control input resistance			40		$\text{k}\Omega$
Gain control bandwidth	Small signal - 3 dB		15		MHz
VOLTAGE CLAMPING					
Output voltages ($V_{OUT\pm}$) relative to clamp voltages ($V_{CL\pm}$)	Device In voltage limiting mode, $T_A = 25^\circ\text{C}$		± 25	± 38	mV
	Device In voltage limiting mode, $T_A = -40^\circ\text{C}$ to $+85^\circ\text{C}$			± 60	
Clamp voltage ($V_{CL\pm}$) input resistance	Device in voltage limiting mode		3.3		$\text{k}\Omega$
Clamp voltage ($V_{CL\pm}$) limits			V_{S-} to V_{S+}		V
POWER SUPPLY					
Specified operating voltage	$T_A = 25^\circ\text{C}$		5	5.5	V
	$T_A = -40^\circ\text{C}$ to $+85^\circ\text{C}$			5.5	
Maximum quiescent current	$T_A = 25^\circ\text{C}$		40	48	mA
	$T_A = -40^\circ\text{C}$ to $+85^\circ\text{C}$			49	
Power supply rejection ($\pm\text{PSRR}$)	$T_A = 25^\circ\text{C}$	70	77		dB
	$T_A = -40^\circ\text{C}$ to $+85^\circ\text{C}$	45			
POWER DOWN					
Enable voltage threshold	TTL low = shut down, $T_A = 25^\circ\text{C}$		1.4		V
	TTL low = shut down, $T_A = -40^\circ\text{C}$ to $+85^\circ\text{C}$	1			
Disable voltage threshold	TTL high = normal operation, $T_A = 25^\circ\text{C}$		1.4		V
	TTL high = normal operation, $T_A = -40^\circ\text{C}$ to $+85^\circ\text{C}$			1.65	
Power-down quiescent current	$T_A = 25^\circ\text{C}$		0.35	0.4	mA
	$T_A = -40^\circ\text{C}$ to $+85^\circ\text{C}$			0.45	
Input current high	$T_A = 25^\circ\text{C}$		± 9	± 16	μA
	$T_A = -40^\circ\text{C}$ to $+85^\circ\text{C}$			± 19	
Input current low	$T_A = 25^\circ\text{C}$		± 109	± 116	μA
	$T_A = -40^\circ\text{C}$ to $+85^\circ\text{C}$			± 119	
Input impedance			$50 \parallel 1$		$\text{k}\Omega \parallel \text{pF}$
Turnon time delay	Measured to 50% quiescent current		820		ns
Turnoff time delay	Measured to 50% quiescent current		500		ns
Forward isolation in power down			80		dB
Input resistance in power down			> 1		$\text{M}\Omega$
Output resistance in power down			16		$\text{k}\Omega$

(1) Slew rate and settling time measured at amplifier output.

6.6 Package Thermal Data

PACKAGE	PCB	$T_A = 25^\circ\text{C}$ POWER RATING ⁽¹⁾
PWP (14-pin) ⁽²⁾	See # 11.	3 W

- (1) This data was taken using 2 oz trace and copper pad that is soldered directly to a 3 in × 3 in PCB.
 (2) The THS7530 incorporates a PowerPAD on the underside of the chip. The PowerPAD acts as a heatsink and must be connected to a thermally dissipative plane for proper power dissipation. Failure to do so may result in exceeding the maximum junction temperature which could permanently damage the device. See TI technical briefs [SLMA002](#) and [SLMA004](#) for more information about using the PowerPAD thermally enhanced package.

6.7 Typical Characteristics

Measured using the AC test circuit shown in [图 7-1](#) (unless otherwise noted).

表 6-1. Table Of Graphs

		FIGURE
Voltage Gain to Load	vs Frequency (Input at 45 dBm)	图 6-1
Gain and Gain Error	vs V_{G+}	图 6-2
Noise Figure	vs Frequency	图 6-3
Output Intercept Point	vs Frequency	图 6-4
1-dB Compression Point	vs Frequency	图 6-5
Total Input Voltage Noise	vs Frequency	图 6-6
Intermodulation Distortion	vs Frequency	图 6-7
Harmonic Distortion	vs Frequency	图 6-8
S-Parameters	vs Frequency	图 9-7
Differential Input Impedance of Main Amplifier	vs Frequency	图 9-8
Differential Output Impedance of Main Amplifier	vs Frequency	图 6-9
V_{G+} Input Impedance	vs Frequency	图 6-10
V_{OCM} Input Impedance	vs Frequency	图 6-11
Common-Mode Rejection Ratio	vs Frequency	图 6-12
Step Response: $2 V_{PP}$	vs Time	图 6-13
Step Response: Rising Edge	vs Time	图 6-14
Step Response: Falling Edge	vs Time	图 6-15

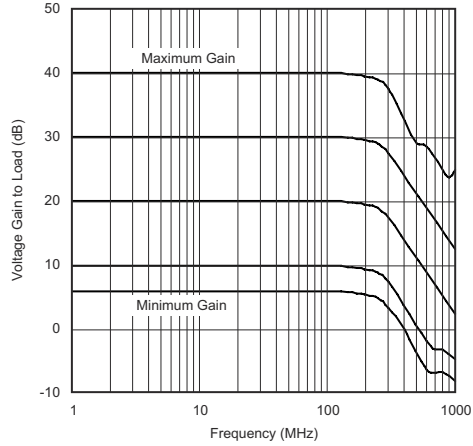

Gain is taken at load. Add 6 dB to refer to amplifier output
 $P_{IN} = -45 \text{ dBm}$

图 6-1. Voltage Gain to Load vs Frequency



图 6-2. Gain and Gain Error vs V_{G+}



Terminated input

图 6-3. Noise Figure vs Frequency

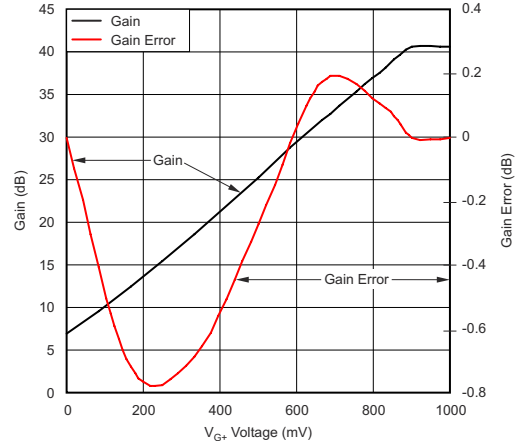
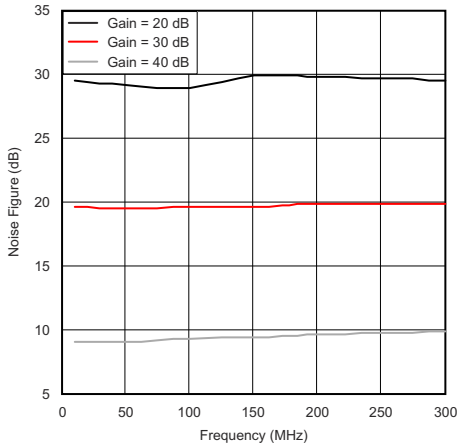
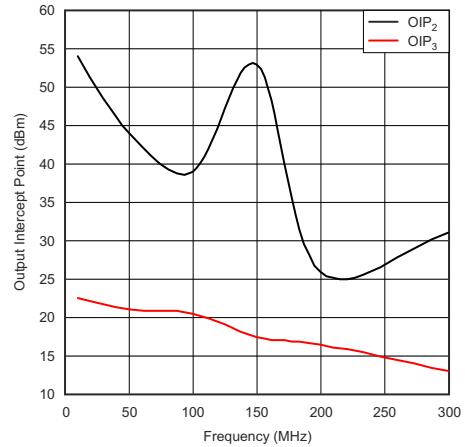

Taken at load. Add 3 dB to refer to amplifier output.

图 6-4. Output Intercept Point vs Frequency

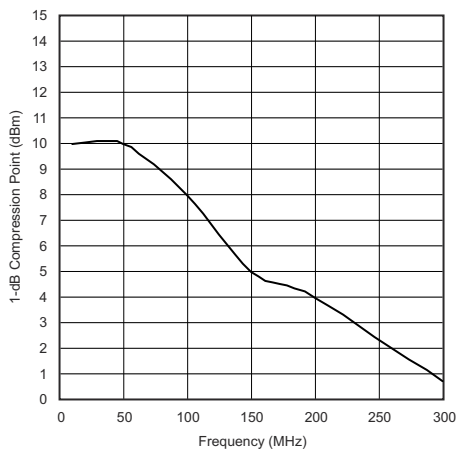

Taken at load. Add 3 dB to refer to amplifier output.

图 6-5. 1-dB Compression Point vs Frequency



图 6-6. Total Input Voltage Noise vs Frequency



$V_{G+} = 1\text{ V}$ $V_O = 1\text{ V}_{PP}$ (composite) $R_L = 400\ \Omega$

图 6-7. Intermodulation Distortion vs Frequency

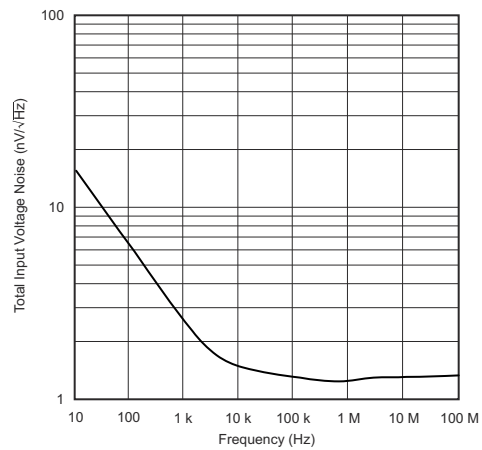
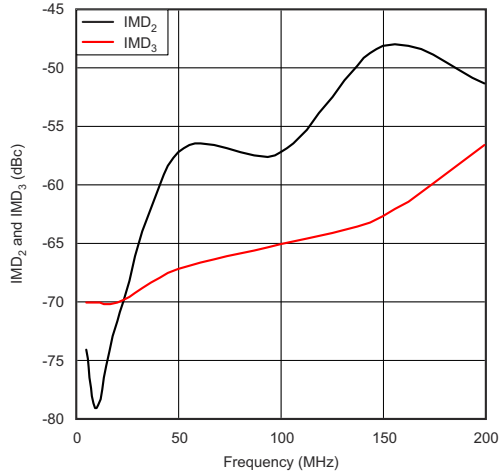
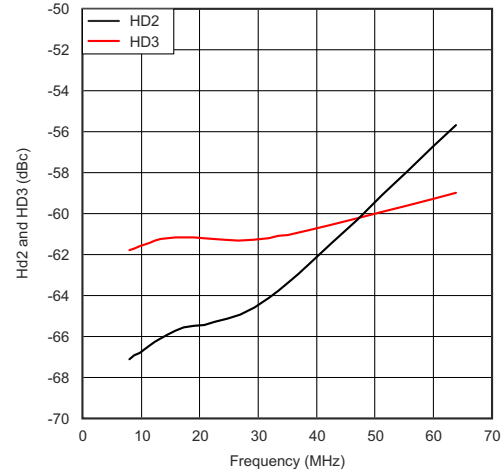

$V_{G+} = 1\text{ V}$ $V_O = 1\text{ V}_{PP}$ $R_L = 400\ \Omega$

图 6-8. Harmonic Distortion vs Frequency



图 6-9. Differential Output Impedance of Main Amplifier vs Frequency



图 6-10. V_{G+} Input Impedance vs Frequency

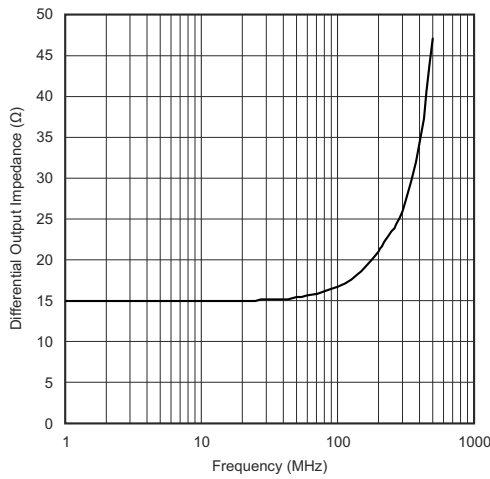

图 6-11. V_{OCM} Input Impedance vs Frequency

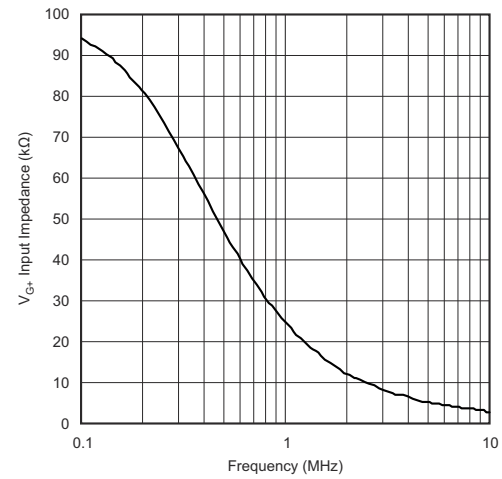

图 6-12. Common-Mode Rejection Ratio vs Frequency

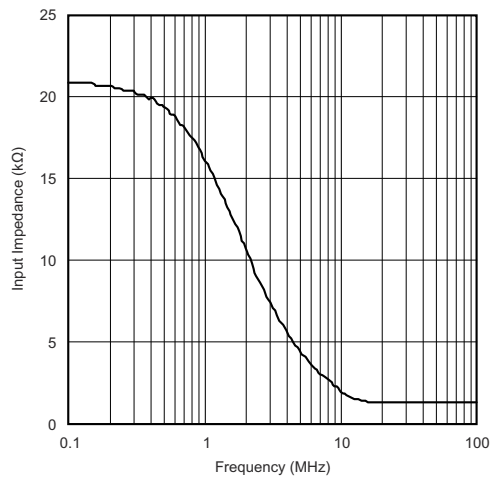

$R_L = 400 \Omega$ At amplifier output and minimum gain

图 6-13. Step Response

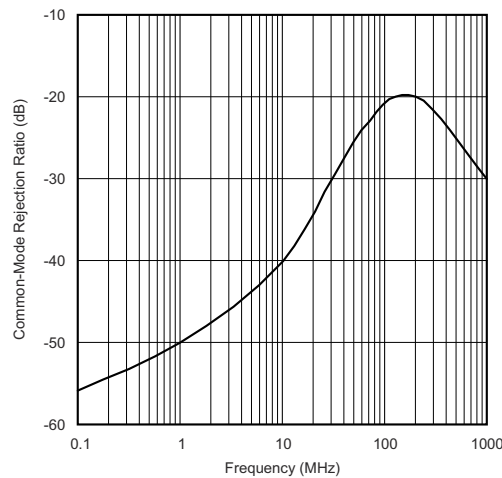
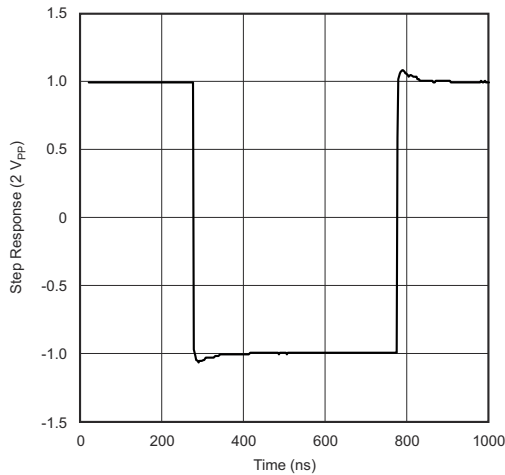
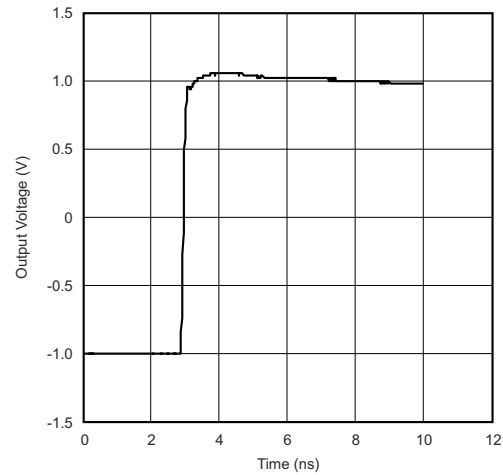

$R_L = 400 \Omega$ At amplifier output and minimum gain

图 6-14. Step Response: Rising Edge

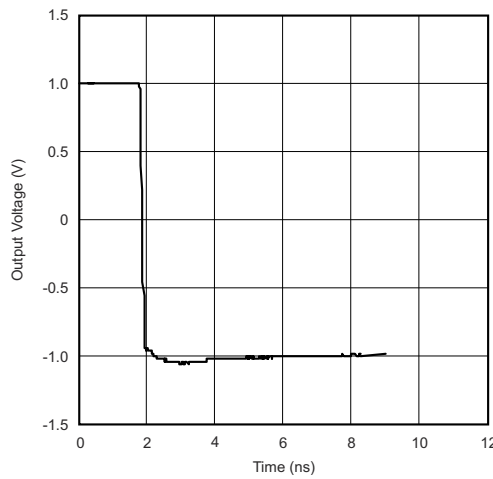

$R_L = 400 \Omega$ At amplifier output and minimum gain

图 6-15. Step Response: Falling Edge

7 Parameter Measurement Information

7.1 Test Circuits



图 7-1. AC Test Circuit



图 7-2. DC Test Circuit

8 Detailed Description

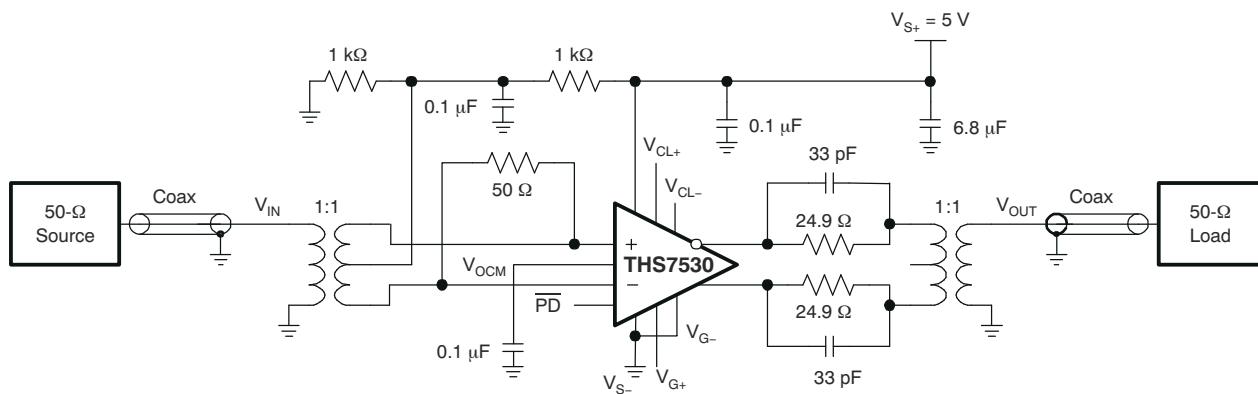
8.1 Overview

The THS7530 device is a fully-differential amplifier with 300-MHz bandwidth and with continually-variable gain from 11.6 dB to 46.5 dB. This amplifier together with an automatic gain control (AGC) circuit will precisely established a desired amplitude at its output.

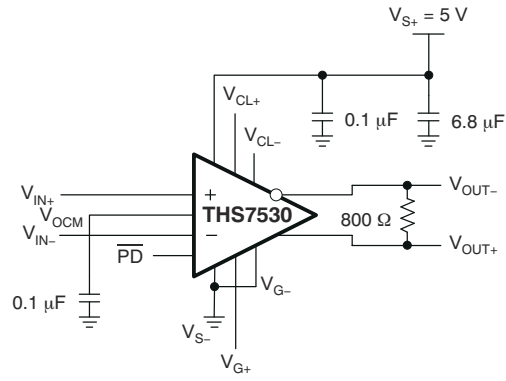
The input architecture is a modified Gilbert cell. The output from the Gilbert cell is converted to a voltage and buffered to the output as a fully-differential signal. A summing node between the outputs is used to compare the output common-mode voltage to the V_{OCM} input. The V_{OCM} error amplifier then servos the output common-mode voltage to maintain it equal to the V_{OCM} input. Left unterminated, V_{OCM} is set to midsupply by internal resistors.

The gain control input is conditioned to give linear-in-dB gain control (block H). The gain control input is a differential signal from 0 V to 0.9 V which varies the gain from 11.6 dB to 46.5 dB.

V_{CL+} and V_{CL-} provide inputs that limit the output voltage swing of the amplifier.

8.2 Functional Block Diagram

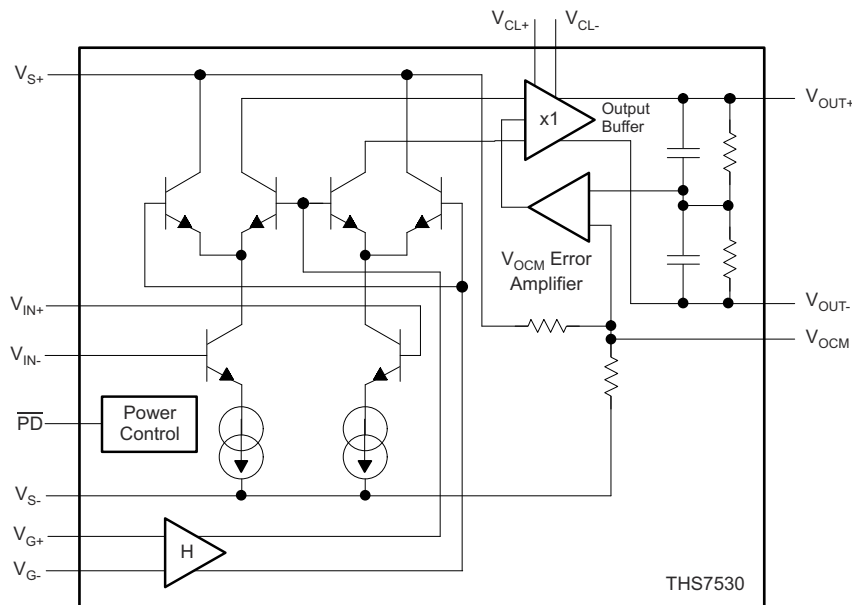

8.3 Feature Description

The main features of the THS7530 device are continually-variable gain control, common-mode voltage control, output voltage clamps, and power-down mode.

8.3.1 Continually-Variable Gain Control

The amplifier gain in dB is a linear function of the gain control voltage, which has a range of 0 V to 0.9 V. The slope of the gain control input is 38.8 dB/V with a gain range of 11.6 dB to 46.5 dB, which is 3.8 to 211.3 V/V, respectively. The bandwidth of the gain control is 15 MHz, typically.

The gain control is a differential input to reduce noise due to ground bounce, coupling, and so forth. The negative gain-control input V_{G-} can be below the negative supply by as much as 600 mV.

8.3.2 Common-Mode Voltage Control

The common-mode voltage control sets the common-mode voltage of the differential output. The gain of the control voltage is 1 V/V with a range of 1.75 V to 3.25 V above the negative supply. If unconnected, the common-mode voltage control is at mid-supply, typically 2.5 V above the negative supply. The bandwidth of the common-mode voltage control is an impressive 32 MHz.

8.3.3 Output Voltage Clamps

Separate inputs, V_{CL-} and V_{CL+} , establish the minimum and maximum output voltages, respectively. The typical error of the output voltage compared to the clamp voltage is only 25 mV. This feature can be used to avoid saturating the inputs of a receiving device, thereby precluding long recovery times in the signal path.

8.3.4 Power-Down Mode

To minimize power consumption when idle, the THS7530 device has an active-low power-down control that reduces the quiescent current from 40 mA to 350 μ A. The turnon delay is only 820 ns.

When in power-down mode, the THS7530 device has a 80-dB forward isolation to allow other devices to drive the same signal path with minimal interference from the idle THS7530 device.

8.4 Device Functional Modes

The THS7530 device has two functional modes: full-power mode and power-down mode. The power-down mode reduces the quiescent current of the device to 350 μ A from a typical value of 40 mA.

With a turnon time of only 820 ns and a turnoff time of 500 ns, the power-down mode can be used to greatly reduce the average power consumption of the device without sacrificing system performance.

9 Application and Implementation

备注

以下应用部分的信息不属于 TI 组件规范，TI 不担保其准确性和完整性。客户应负责确定 TI 组件是否适用于其应用。客户应验证并测试其设计，以确保系统功能。

9.1 Application Information

The THS7530 device is designed to work in a wide variety of applications requiring continuously variable gain and a fully-differential signal path. The common-mode voltage control and the output voltage clamps enable the THS7530 device to drive a diverse array of receiving circuits.



图 9-1. EVM Schematic: Designed for Use With Typical 50-Ω RF Test Equipment



图 9-2. AC-Coupled Single-Ended Input With AC-Coupled Differential Output

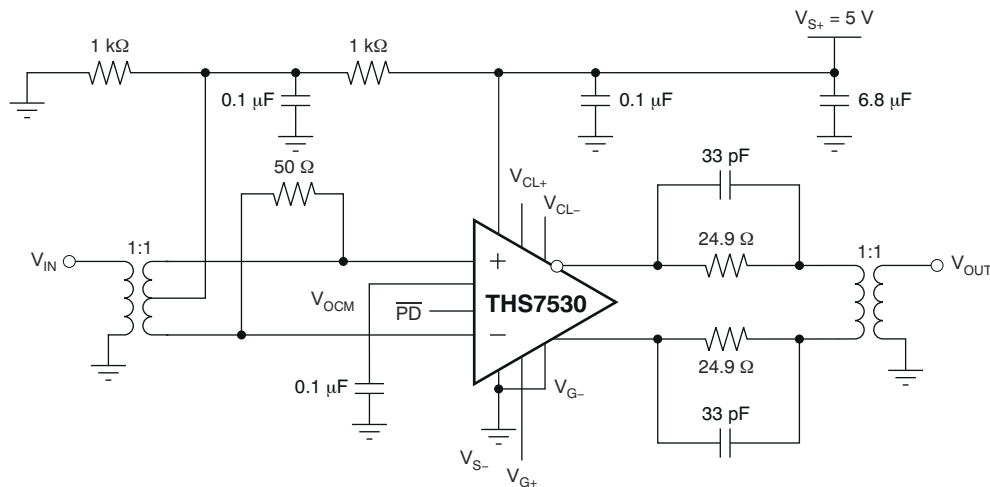

图 9-3. AC-Coupled Differential Input With AC-Coupled Differential Output

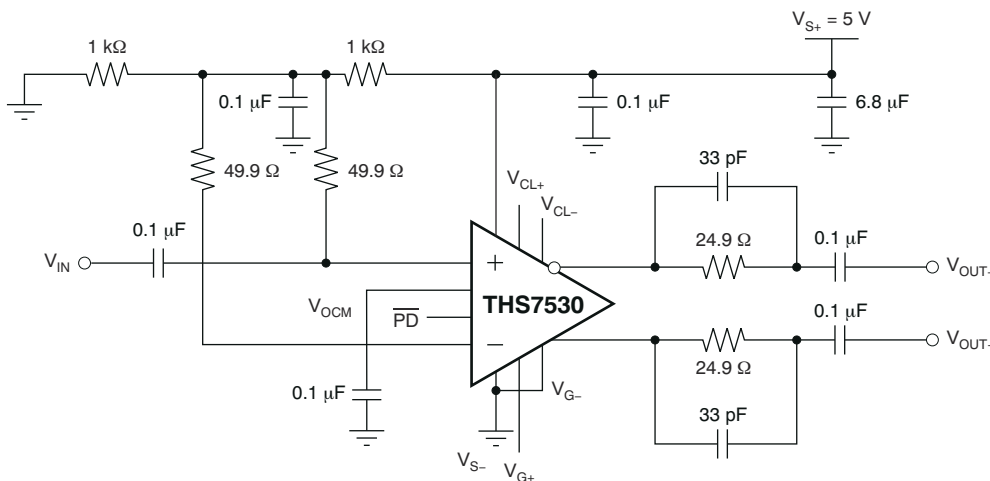

图 9-4. DC-Coupled Single-Ended Input With DC-Coupled Differential Output

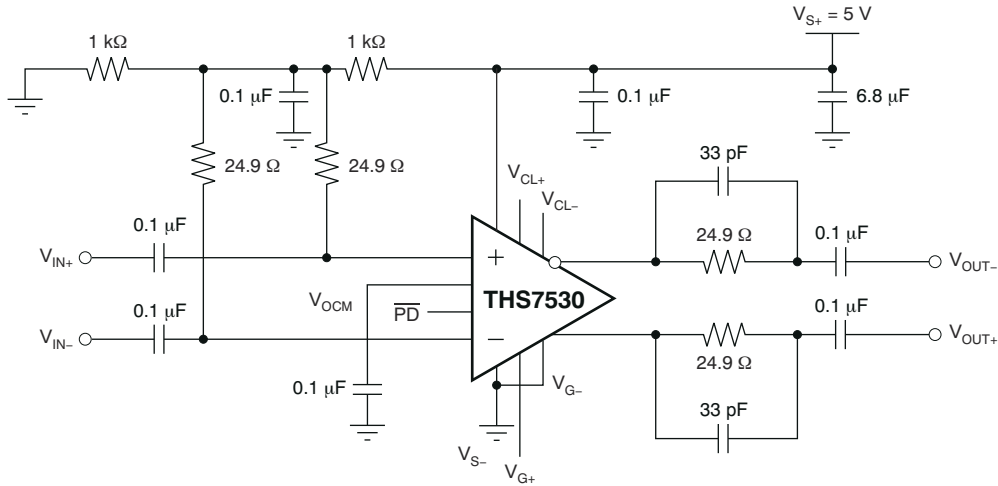

图 9-5. DC-Coupled Differential Input With DC-Coupled Differential Output

9.2 Typical Application

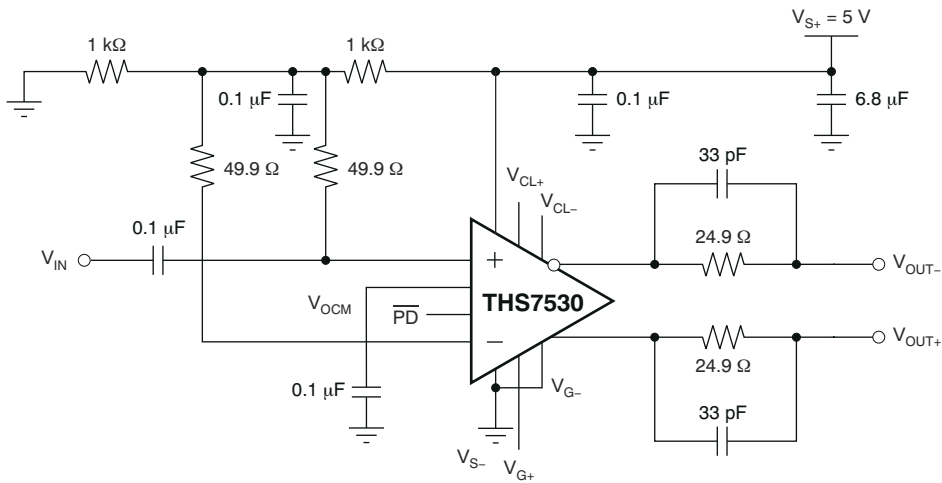

图 9-6. Typical Application Circuit

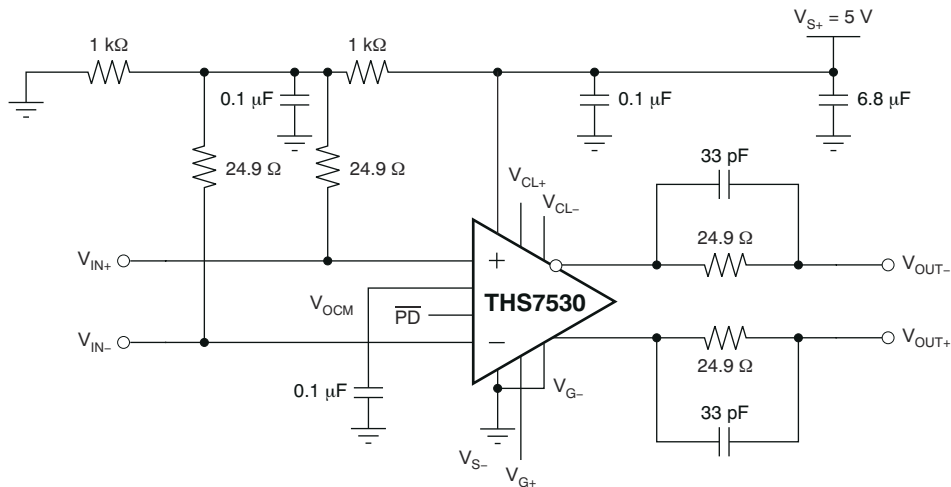
9.2.1 Design Requirements

A typical application circuit is shown in [图 9-6](#). Two noteworthy aspects of this circuit are the customer's automatic gain control (AGC) circuit and the THS7530 input bias circuit.

The proper design of the AGC circuit is essential for the THS7530 device to operate properly in the customer's application. The method of detecting the amplitude of the differential output of the THS7530 device and creating the gain-control voltage, V_{G+} , from the detected amplitude and the reference amplitude, V_{ref} , are application-specific and beyond the scope of this document. The bandwidth of the amplitude of the THS7530 amplitude control is 15 MHz, which allows for rapid corrections of amplitude errors but which also allows noise from DC to 15 MHz to create an amplitude error. The trade-off between rapid amplitude correction and amplitude modulation due to noise is an important design consideration.

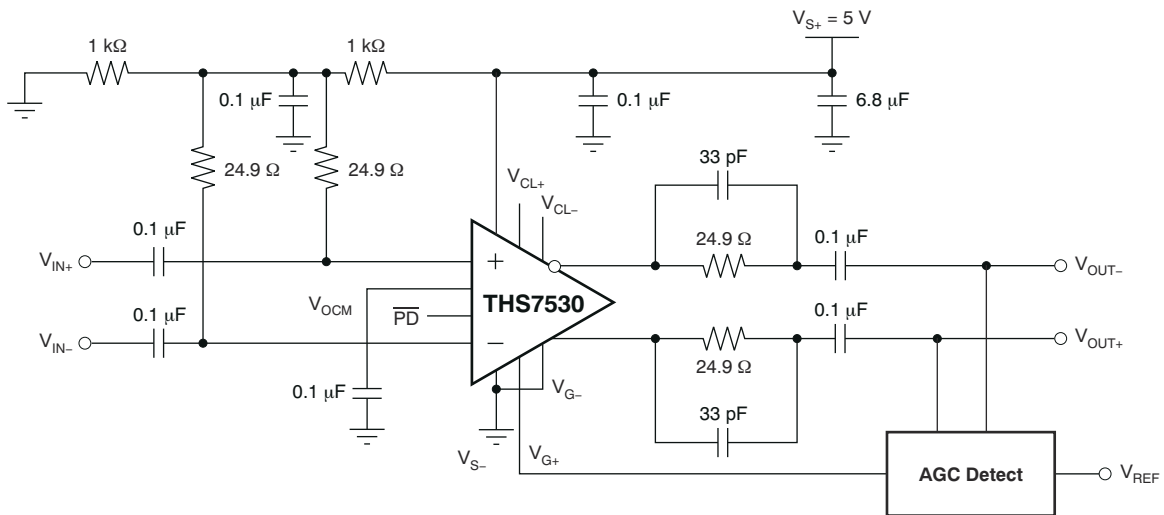
The input bias currents of the differential inputs of the THS7530 device are typically 20 μ A. When the differential inputs are AC-coupled, the bias currents must be supplied as shown in [图 9-6](#). In this circuit, the DC bias voltage is mid-supply and the AC differential input impedance is 50 Ω . The 0.1- μ F capacitor between the two 24.9- Ω resistors creates an AC ground for the driving circuit.

9.2.2 Detailed Design Procedure

The THS7530 device is designed for nominal 5-V power supply from V_{S+} to V_{S-} .

The amplifier has fully differential inputs, V_{IN+} and V_{IN-} , and fully differential outputs, V_{OUT+} and V_{OUT-} . The inputs are high impedance and outputs are low impedance. External resistors are recommended for impedance matching and termination purposes.

The inputs and outputs can be DC-coupled, but for best performance, the input and output common-mode voltage should be maintained at the midpoint between the two supply pins. The output common-mode voltage is controlled by the voltage applied to V_{OCM} . Left unterminated, V_{OCM} is set to midsupply by internal resistors. A 0.1- μ F bypass capacitor should be placed between V_{OCM} and ground to reduce common-mode noise. The input common-mode voltage defaults to midrail when left unconnected. For voltages other than midrail, V_{OCM} must be biased by external means. V_{IN+} and V_{IN-} both require a nominal 30- μ A bias current for proper operation. Therefore, ensure equal input impedance at each input to avoid generating an offset voltage that varies with gain.

Voltage applied from V_{G-} to V_{G+} controls the gain of the part with 38.8-dB/V gain slope. The input can be differential or single ended. V_{G-} must be maintained within -0.6 V and 0.8 V of V_{S-} for proper operation. The negative gain input should typically be tied directly to the negative power supply.

V_{CL+} and V_{CL-} are inputs that limit the output voltage swing of the amplifier. The voltages applied set an absolute limit on the voltages at the output. Input voltages at V_{CL+} and V_{CL-} clamp the output, ensuring that neither output exceeds those values.

The power-down input is a TTL compatible input, referenced to the negative supply voltage. A logic low puts the THS7530 device in power-saving mode. In power-down mode the part consumes less than 1-mA current, the output goes high impedance, and a high amount of isolation is maintained between the input and output.

Power-supply bypass capacitors are required for proper operation. A 6.8- μ F tantalum bulk capacitor is recommended if the amplifier is located far from the power supply and may be shared among other devices. A ceramic 0.1- μ F capacitor is recommended within 0.1-in of the device power pin. The ceramic capacitors should be located on the same layer as the amplifier to eliminate the use of vias between the capacitors and the power pin.

表 9-1. THS7530EVM Bill of Materials

ITEM NO.	DESCRIPTION	SIZE	REFERENCE DESIGNATOR	QTY	PART NUMBER
1	Bead, ferrite, 3 A, 80 Ω	1206	FB1	1	(Steward) HI1206N800R - 00
2	Capacitor, tantalum, 6.8 mF, 35 V, 10%	D	C2	1	(AVX) TAJD685K035R
3	Capacitor, ceramic, 0.1 mF, X7R, 16V	508	C1	1	(AVX) 0508YC104KAT2A
5	Capacitor, ceramic, 0.1 mF, X7R, 50 V	805	C3, C7, C12, C13, C14, C15, C16, C17	8	(AVX) 08055C104KAT2A
6	Diode, Schottky, 20 V, 0.5 A	SOD-123	D1	1	(Diodes Inc.) B0520LW - 7
7	Resistor, 10 Ω , 1/8 W, 1%	805	R24, R25, R26	3	(PHYCOMP) 9C08052A10R0FKHFT
8	Resistor, 24.9 Ω , 1/8 W, 1%	805	R9, R15	2	(PHYCOMP) 9C08052A24R9FKHFT
9	Resistor, 1 k Ω , 1.8W, 1%	805	R7, R12	2	(PHYCOMP) 9C08052A1001FKHFT
10	Resistor, 3.92 k Ω , 1/8 W, 1%	805	R1	1	(PHYCOMP) 9C08052A3921FKHFT
11	Resistor, 0 Ω , 1/4 W	1206	C4, C5	2	(PHYCOMP) 9C12063A0R00JLHFT
12	Resistor, 49.9 Ω , 1/4 W, 1%	1206	R4	1	(PHYCOMP) 9C12063A49R9FKRFT
13	Pot., ceramic, 1/4 inch square, 1 k Ω		R2	1	(Bourns) 3362P - 1 - 102
14	Pot., ceramic, 1/4 inch square, 10 k Ω		R21, R22, R23	3	(Bourns) 3362P - 1 - 103
15	IC, TLV2371	SOT-23	U2, U3, U4	3	(TI) TLV2371IDBVT
16	Transformer, 1:1	CD542	T1, T2	2	(Mini-Circuits) ADT1-1WT
17	Connector, edge, SMA PCB Jack		J3, J4	2	(Johnson) 142 - 0701 - 801
18	Jack, banana receptacle, 0.25-in diameter hole		J1, J2	2	(HH Smith) 101
19	Header, 0.1-in Ctrs, 0.025-in square pins	2 POS.	JP1	1	(Sullins) PZC36SAAN
20	Shunts		JP1	1	(Sullins) SSC02SYAN
21	Test point, black		TP2, TP3, TP4	3	(Keystone) 5001
22	Test points, red		TP1, TP8, TP9, TP10	4	(Keystone) 5000
23	Standoff, 4 - 40 Hex, 0.625-in Length			4	(Keystone) 1804
24	Screw, Phillips, 4 - 40, .250-in			4	SHR - 0440 - 016 - SN
25	IC, THS7530		U1	1	(TI) THS7530PWP
26	Board, printed circuit			1	(TI) EDGE # 6441987

9.2.3 Application Curves

图 9-7 和 图 9-8 highlight the input characteristics of the THS7530 device that should be used to design the circuit driving the THS7530 device.



图 9-7. S-Parameters vs Frequency



图 9-8. Differential Input Impedance of Main Amplifier vs Frequency

10 Power Supply Recommendations

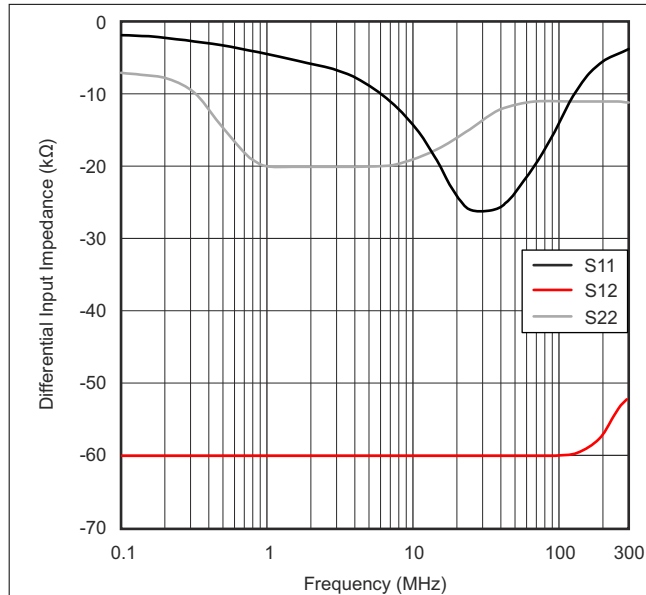
The THS7530 device is principally intended to operate with a nominal single-supply voltage of 5 V. Supply voltage tolerances of $\pm 10\%$ are supported. The absolute maximum supply is 5.5 V.

Supply decoupling is required, as described in 节 9.

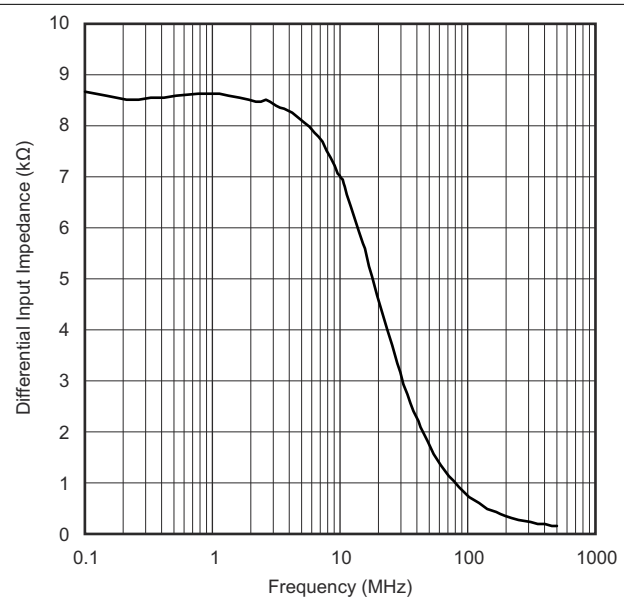
Split (or bipolar) supplies can be used with the THS7530 device, as long as the total value across the device remains less than 5.5 V (absolute maximum).

11 Layout

11.1 Layout Guidelines

The THS7530 device is available in a thermally-enhanced PowerPAD™ package. 图 11-1 shows the recommended number of vias and thermal land size recommended for best performance. Thermal vias connect the thermal land to internal or external copper planes and should have a drill diameter sufficiently small so that the via hole is effectively plugged when the barrel of the via is plated with copper. This plug is needed to prevent wicking the solder away from the interface between the package body and the thermal land on the surface of the board during solder reflow. The experiments conducted jointly with Solectron Texas indicate that a via drill diameter of 0.33 mm (13 mils, or .013 in) or smaller works well when 1-ounce copper is plated at the surface of the board and simultaneously plating the barrel of the via. If the thermal vias are not plugged when the copper plating is performed, then a solder mask material should be used to cap the vias with a dimension equal to the via diameter + 0.1 mm minimum. This prevents the solder from being wicked through the thermal via and potentially creating a solder void in the region between the package bottom and the thermal land on the surface of the PCB.



图 11-1. Recommended Thermal Land Size and Thermal Via Patterns (Dimensions in mm)

See TI's Technical Brief titled, *PowerPAD™ Thermally Enhanced Package* (SLMA002) for a detailed discussion of the PowerPAD™ package, its dimensions, and recommended use.

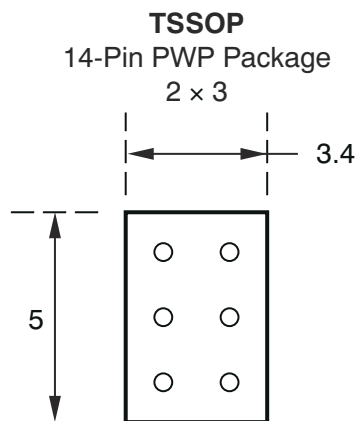

图 11-2. EVM Schematic

11.2 Layout Examples



图 11-3. Layout Diagram (Top)

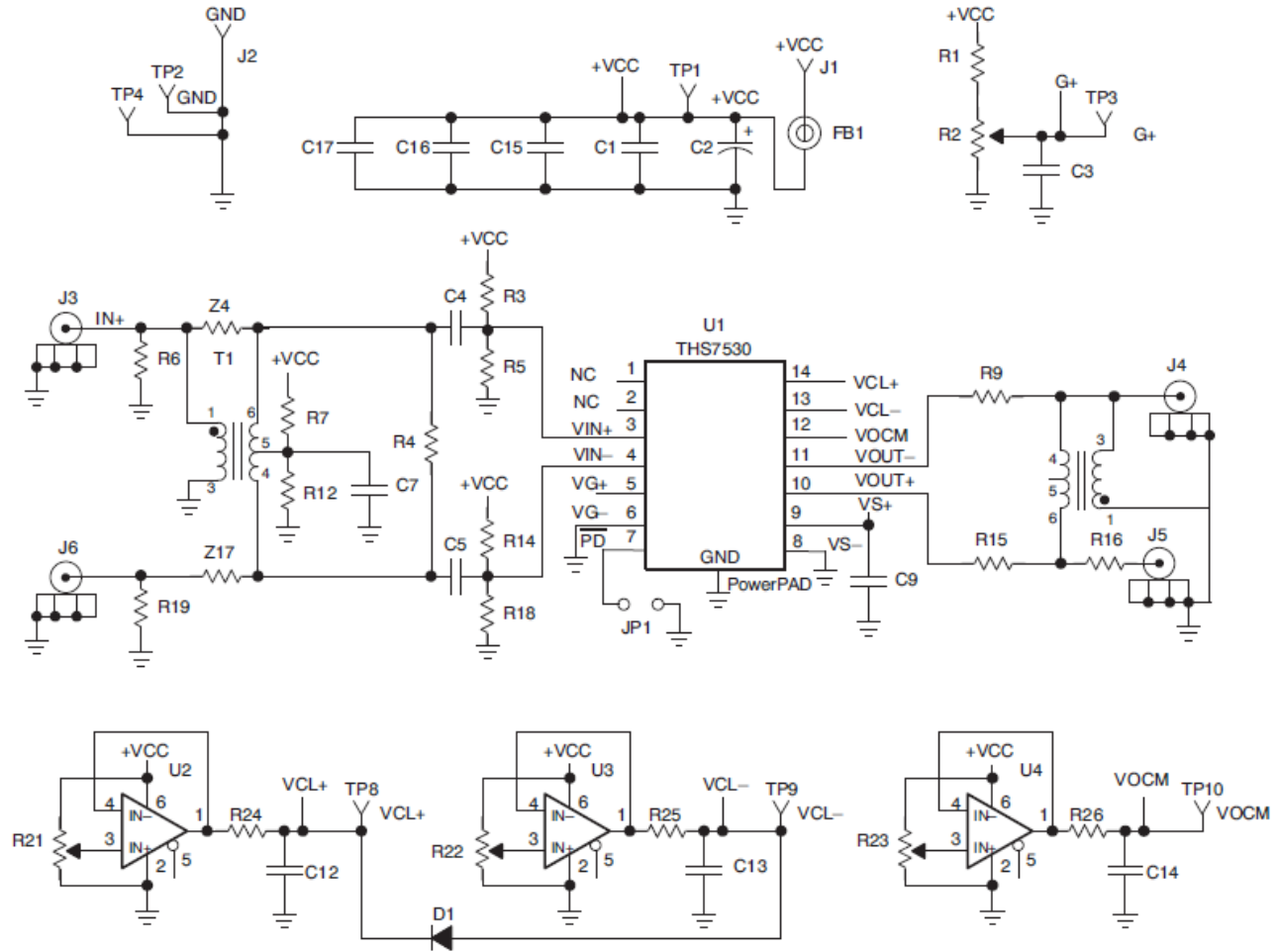

图 11-4. Layout Diagram (Ground)

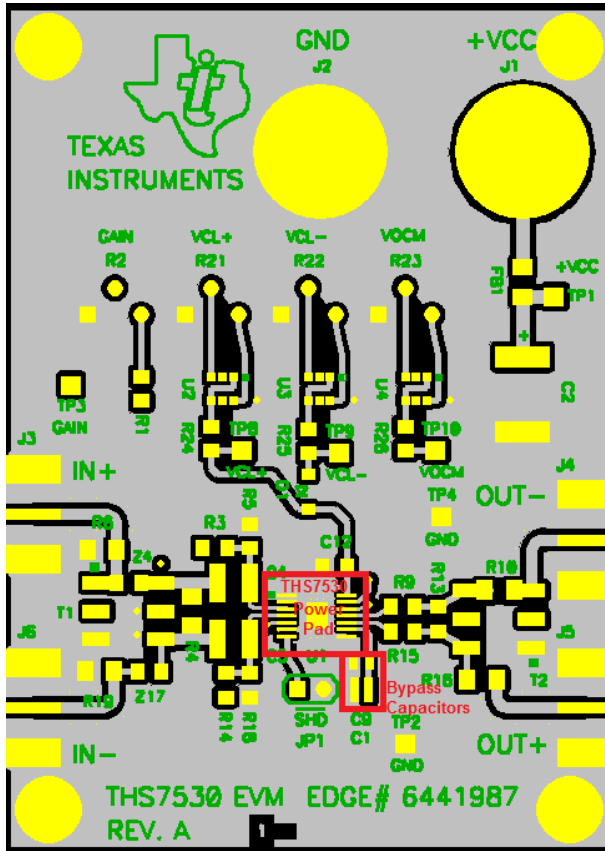

图 11-5. Layout Diagram (Power)

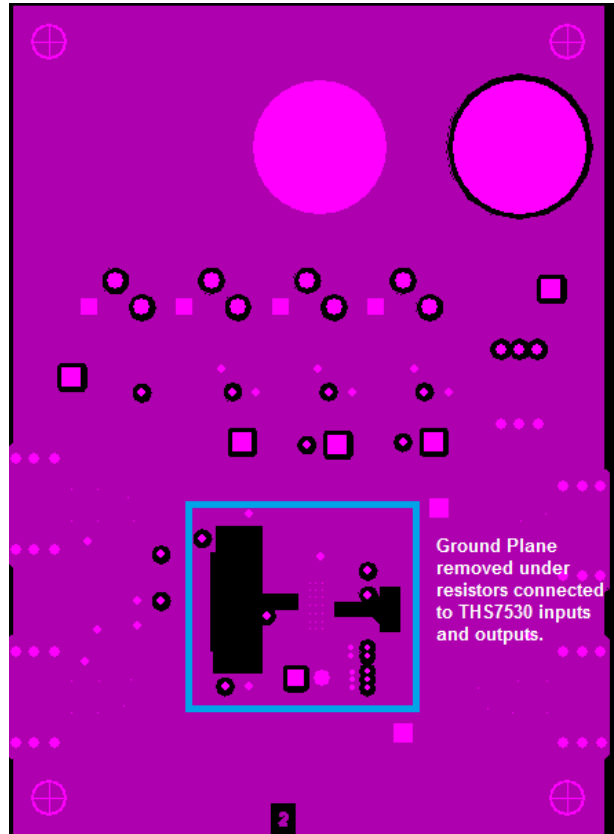

图 11-6. Layout Diagram (Bottom)

12 Device and Documentation Support

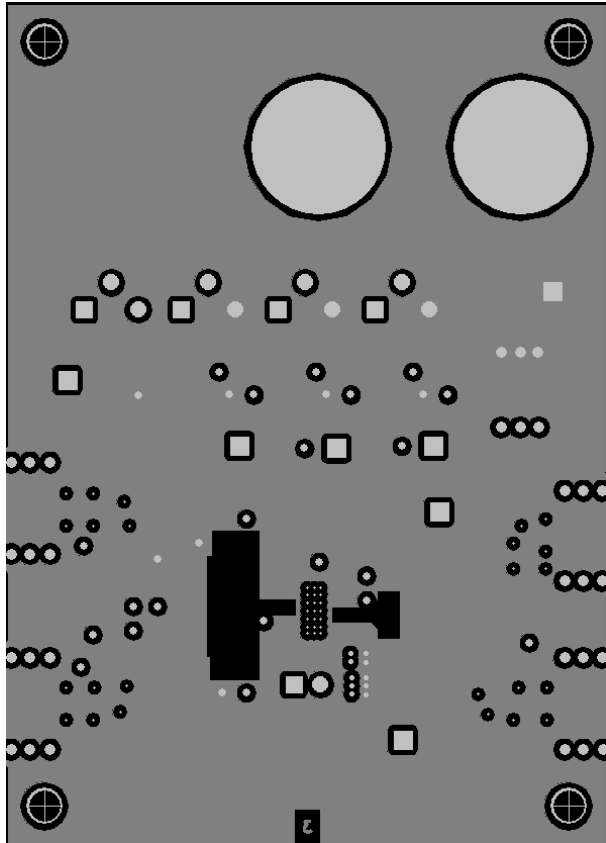
12.1 Device Support

12.1.1 第三方产品免责声明

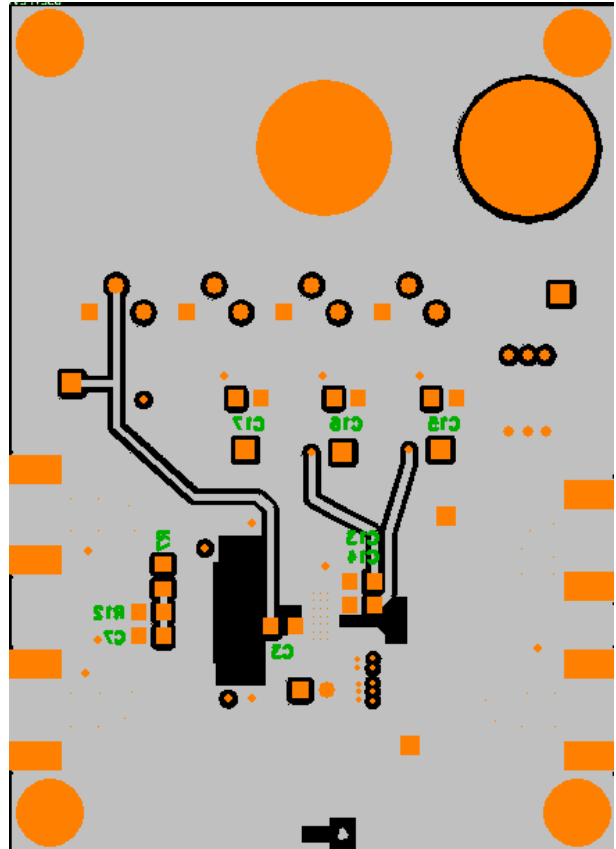
TI 发布的与第三方产品或服务有关的信息，不能构成与此类产品或服务或保修的适用性有关的认可，不能构成此类产品或服务单独或与任何 TI 产品或服务一起的表示或认可。

12.1.2 Development Support

For the THS7530 PSpice Model, see [SLOJ139](#).

For the THS7530 TINA-TI Spice Model, see [SLAM020](#).

For the THS7530 TINA-TI Reference Design, see [SLAC091](#).

12.2 Documentation Support

12.2.1 Related Documentation

For related documentation, see the following:

- *THS7530 EVM Users Guide*, [SLOU161](#)
- *Noise Analysis for High-Speed Op Amps*, [SBOA066](#)
- *TI's Analog Signal Chain Guide*, [SLYB174](#)
- *PowerPAD™ Thermally Enhanced Package*, [SLMA002](#)
- *PowerPAD™ Made Easy*, [SLMA004](#)

12.3 支持资源

[TI E2E™ 中文支持论坛](#) 是工程师的重要参考资料，可直接从专家处获得快速、经过验证的解答和设计帮助。搜索现有解答或提出自己的问题，获得所需的快速设计帮助。

链接的内容由各个贡献者“按原样”提供。这些内容并不构成 TI 技术规范，并且不一定反映 TI 的观点；请参阅 TI 的 [使用条款](#)。

12.4 Trademarks

PowerPAD™ is a trademark of Texas Instruments.

TI E2E™ is a trademark of Texas Instruments.

所有商标均为其各自所有者的财产。

12.5 静电放电警告



静电放电 (ESD) 会损坏这个集成电路。德州仪器 (TI) 建议通过适当的预防措施处理所有集成电路。如果不遵守正确的处理和安装程序，可能会损坏集成电路。

ESD 的损坏小至导致微小的性能降级，大至整个器件故障。精密的集成电路可能更容易受到损坏，这是因为非常细微的参数更改都可能会导致器件与其发布的规格不相符。

12.6 术语表

[TI 术语表](#) 本术语表列出并解释了术语、首字母缩略词和定义。

13 Mechanical, Packaging, and Orderable Information

The following pages include mechanical, packaging, and orderable information. This information is the most current data available for the designated devices. This data is subject to change without notice and revision of this document. For browser-based versions of this data sheet, refer to the left-hand navigation.

PACKAGING INFORMATION

Orderable Device	Status (1)	Package Type	Package Drawing	Pins	Package Qty	Eco Plan (2)	Lead finish/ Ball material (6)	MSL Peak Temp (3)	Op Temp (°C)	Device Marking (4/5)	Samples
THS7530PWP	ACTIVE	HTSSOP	PWP	14	90	RoHS & Green	NIPDAU	Level-2-260C-1 YEAR	-40 to 85	THS7530	Samples
THS7530PWPR	ACTIVE	HTSSOP	PWP	14	2000	RoHS & Green	NIPDAU	Level-2-260C-1 YEAR	-40 to 85	THS7530	Samples

(1) The marketing status values are defined as follows:

ACTIVE: Product device recommended for new designs.

LIFEBUY: TI has announced that the device will be discontinued, and a lifetime-buy period is in effect.

NRND: Not recommended for new designs. Device is in production to support existing customers, but TI does not recommend using this part in a new design.

PREVIEW: Device has been announced but is not in production. Samples may or may not be available.

OBSOLETE: TI has discontinued the production of the device.

(2) **RoHS:** TI defines "RoHS" to mean semiconductor products that are compliant with the current EU RoHS requirements for all 10 RoHS substances, including the requirement that RoHS substance do not exceed 0.1% by weight in homogeneous materials. Where designed to be soldered at high temperatures, "RoHS" products are suitable for use in specified lead-free processes. TI may reference these types of products as "Pb-Free".

RoHS Exempt: TI defines "RoHS Exempt" to mean products that contain lead but are compliant with EU RoHS pursuant to a specific EU RoHS exemption.

Green: TI defines "Green" to mean the content of Chlorine (Cl) and Bromine (Br) based flame retardants meet JS709B low halogen requirements of <=1000ppm threshold. Antimony trioxide based flame retardants must also meet the <=1000ppm threshold requirement.

(3) MSL, Peak Temp. - The Moisture Sensitivity Level rating according to the JEDEC industry standard classifications, and peak solder temperature.

(4) There may be additional marking, which relates to the logo, the lot trace code information, or the environmental category on the device.

(5) Multiple Device Markings will be inside parentheses. Only one Device Marking contained in parentheses and separated by a "~" will appear on a device. If a line is indented then it is a continuation of the previous line and the two combined represent the entire Device Marking for that device.

(6) Lead finish/Ball material - Orderable Devices may have multiple material finish options. Finish options are separated by a vertical ruled line. Lead finish/Ball material values may wrap to two lines if the finish value exceeds the maximum column width.

Important Information and Disclaimer:The information provided on this page represents TI's knowledge and belief as of the date that it is provided. TI bases its knowledge and belief on information provided by third parties, and makes no representation or warranty as to the accuracy of such information. Efforts are underway to better integrate information from third parties. TI has taken and continues to take reasonable steps to provide representative and accurate information but may not have conducted destructive testing or chemical analysis on incoming materials and chemicals. TI and TI suppliers consider certain information to be proprietary, and thus CAS numbers and other limited information may not be available for release.

In no event shall TI's liability arising out of such information exceed the total purchase price of the TI part(s) at issue in this document sold by TI to Customer on an annual basis.

OTHER QUALIFIED VERSIONS OF THS7530 :

- Automotive : [THS7530-Q1](#)

NOTE: Qualified Version Definitions:

- Automotive - Q100 devices qualified for high-reliability automotive applications targeting zero defects

TAPE AND REEL INFORMATION

QUADRANT ASSIGNMENTS FOR PIN 1 ORIENTATION IN TAPE

*All dimensions are nominal

Device	Package Type	Package Drawing	Pins	SPQ	Reel Diameter (mm)	Reel Width W1 (mm)	A0 (mm)	B0 (mm)	K0 (mm)	P1 (mm)	W (mm)	Pin1 Quadrant
THS7530PWPR	HTSSOP	PWP	14	2000	330.0	12.4	6.9	5.6	1.6	8.0	12.0	Q1

TAPE AND REEL BOX DIMENSIONS

*All dimensions are nominal

Device	Package Type	Package Drawing	Pins	SPQ	Length (mm)	Width (mm)	Height (mm)
THS7530PWPR	HTSSOP	PWP	14	2000	350.0	350.0	43.0

TUBE

*All dimensions are nominal

Device	Package Name	Package Type	Pins	SPQ	L (mm)	W (mm)	T (μm)	B (mm)
THS7530PWP	PWP	HTSSOP	14	90	530	10.2	3600	3.5

GENERIC PACKAGE VIEW

PWP 14

PowerPAD TSSOP - 1.2 mm max height

4.4 x 5.0, 0.65 mm pitch

PLASTIC SMALL OUTLINE

This image is a representation of the package family, actual package may vary.
Refer to the product data sheet for package details.

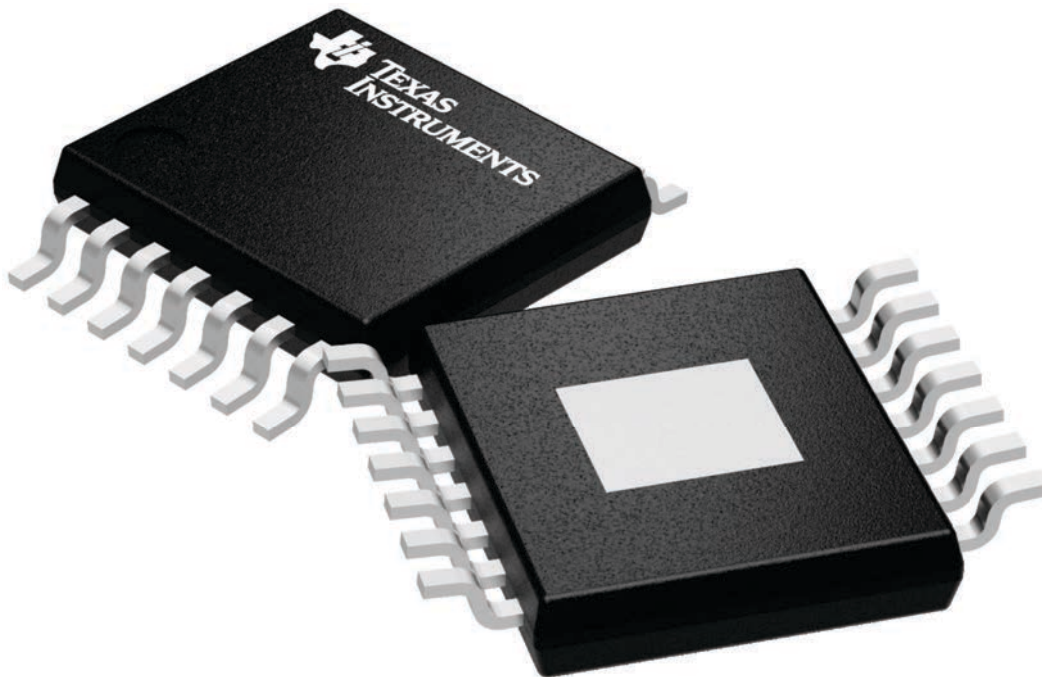

4224995/A

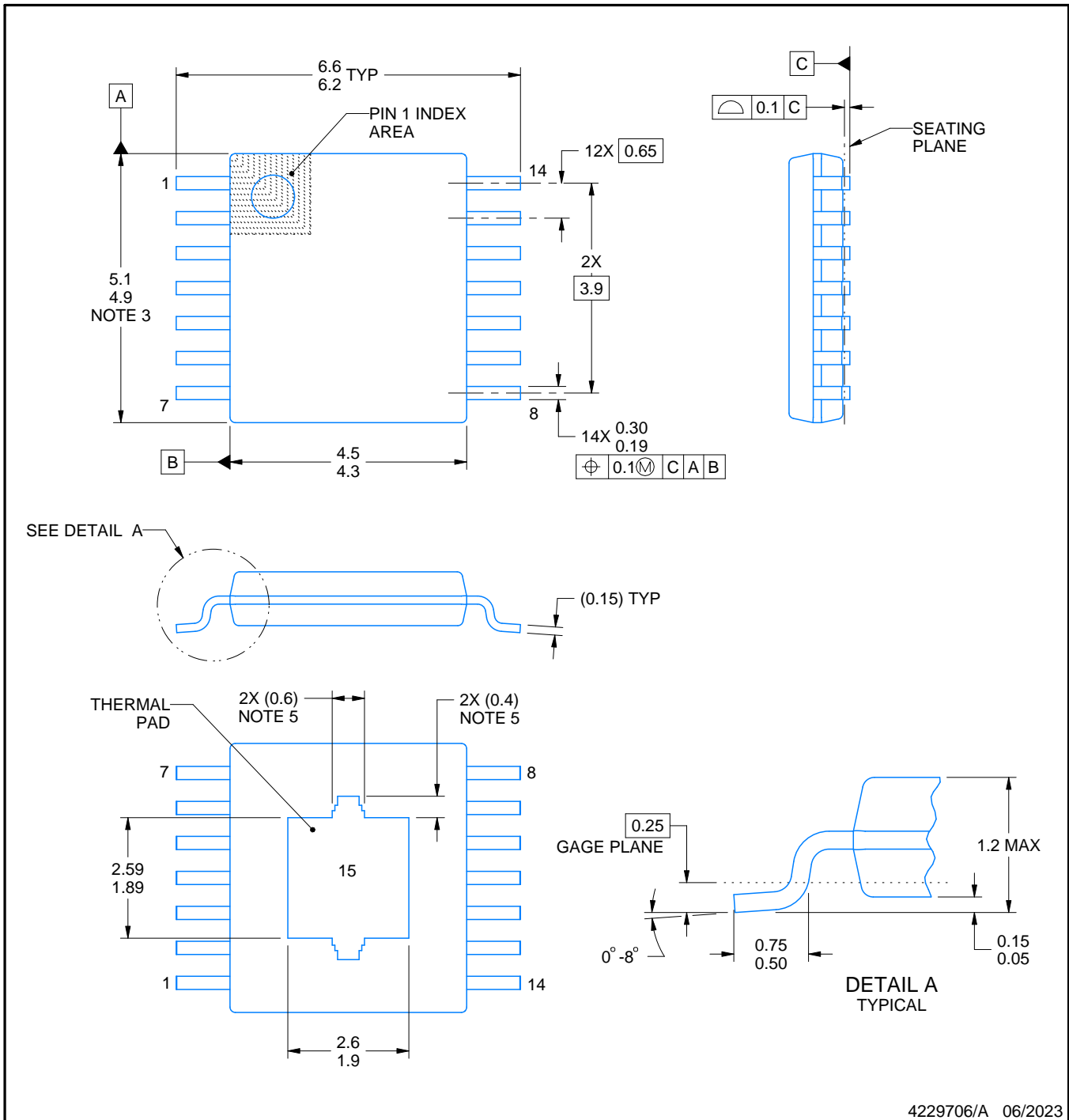
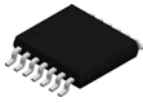

4229706/A 06/2023

NOTES:

PowerPAD is a trademark of Texas Instruments.

1. All linear dimensions are in millimeters. Any dimensions in parenthesis are for reference only. Dimensioning and tolerancing per ASME Y14.5M.
2. This drawing is subject to change without notice.
3. This dimension does not include mold flash, protrusions, or gate burrs. Mold flash, protrusions, or gate burrs shall not exceed 0.15 mm per side.
4. Reference JEDEC registration MO-153.
5. Features may differ or may not be present.

EXAMPLE BOARD LAYOUT

PWP0014K

PowerPAD™ TSSOP - 1.2 mm max height

SMALL OUTLINE PACKAGE

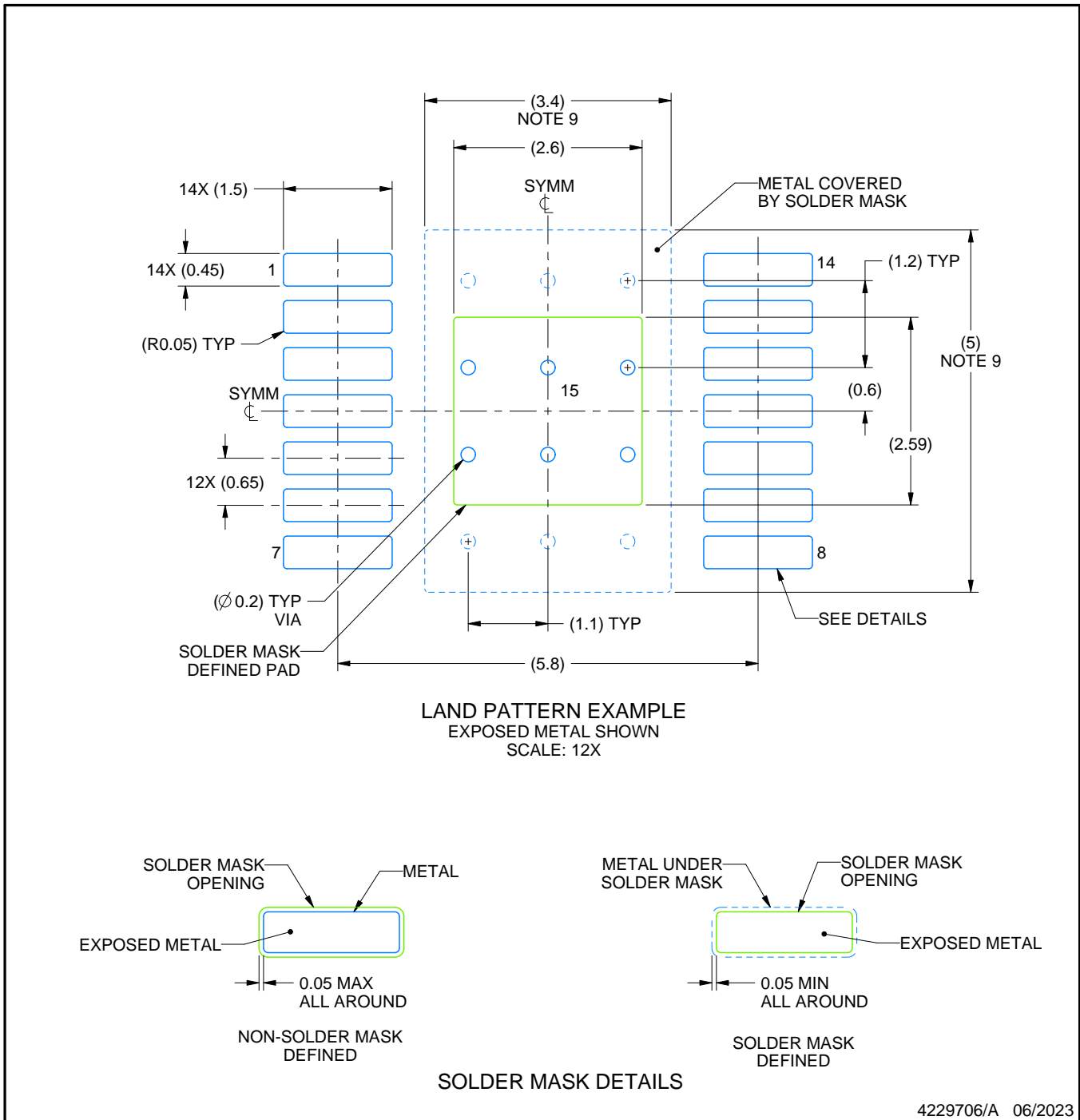

NOTES: (continued)

6. Publication IPC-7351 may have alternate designs.
7. Solder mask tolerances between and around signal pads can vary based on board fabrication site.
8. This package is designed to be soldered to a thermal pad on the board. For more information, see Texas Instruments literature numbers SLMA002 (www.ti.com/lit/slma002) and SLMA004 (www.ti.com/lit/slma004).
9. Size of metal pad may vary due to creepage requirement.
10. Vias are optional depending on application, refer to device data sheet. It is recommended that vias under paste be filled, plugged or tented.

EXAMPLE STENCIL DESIGN

PWP0014K

PowerPAD™ TSSOP - 1.2 mm max height

SMALL OUTLINE PACKAGE

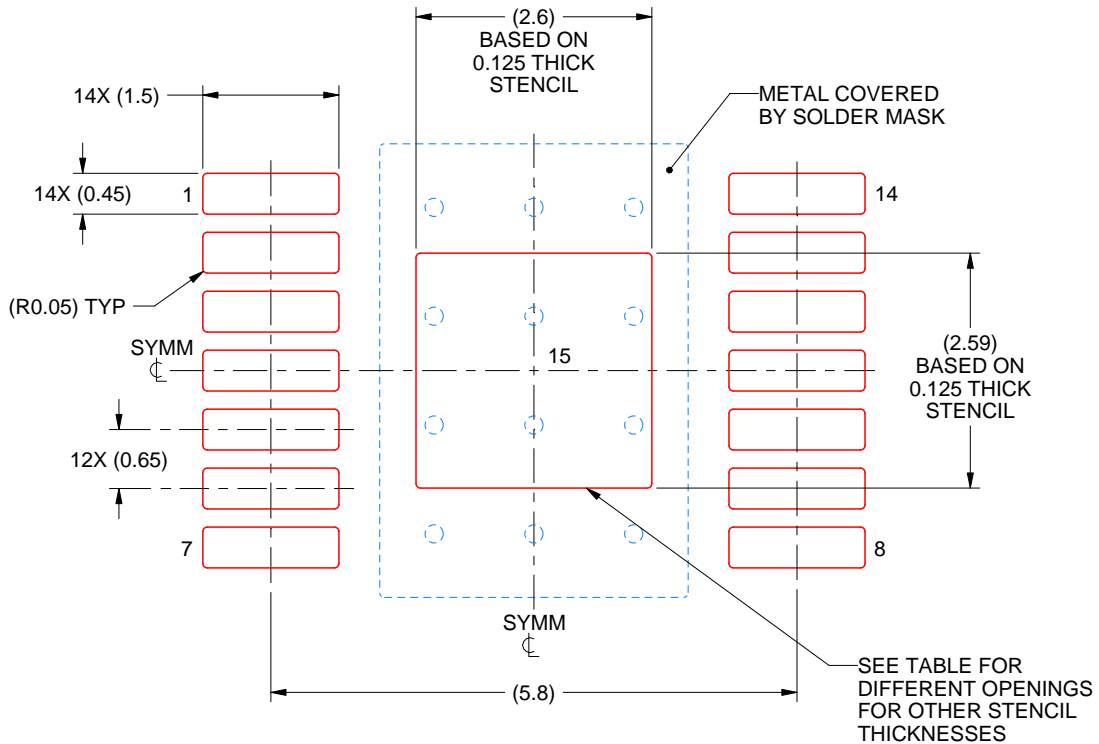

SOLDER PASTE EXAMPLE
BASED ON 0.125 mm THICK STENCIL
SCALE: 12X

STENCIL THICKNESS	SOLDER STENCIL OPENING
0.1	2.91 X 2.90
0.125	2.60 X 2.59 (SHOWN)
0.15	2.37 X 2.36
0.175	2.20 X 2.19

4229706/A 06/2023

NOTES: (continued)

11. Laser cutting apertures with trapezoidal walls and rounded corners may offer better paste release. IPC-7525 may have alternate design recommendations.
12. Board assembly site may have different recommendations for stencil design.

重要声明和免责声明

TI“按原样”提供技术和可靠性数据（包括数据表）、设计资源（包括参考设计）、应用或其他设计建议、网络工具、安全信息和其他资源，不保证没有瑕疵且不做任何明示或暗示的担保，包括但不限于对适销性、某特定用途方面的适用性或不侵犯任何第三方知识产权的暗示担保。

这些资源可供使用 TI 产品进行设计的熟练开发人员使用。您将自行承担以下全部责任：(1) 针对您的应用选择合适的 TI 产品，(2) 设计、验证并测试您的应用，(3) 确保您的应用满足相应标准以及任何其他功能安全、信息安全、监管或其他要求。

这些资源如有变更，恕不另行通知。TI 授权您仅可将这些资源用于研发本资源所述的 TI 产品的应用。严禁对这些资源进行其他复制或展示。您无权使用任何其他 TI 知识产权或任何第三方知识产权。您应全额赔偿因在这些资源的使用中对 TI 及其代表造成的任何索赔、损害、成本、损失和债务，TI 对此概不负责。

TI 提供的产品受 [TI 的销售条款](#) 或 [ti.com](#) 上其他适用条款/TI 产品随附的其他适用条款的约束。TI 提供这些资源并不会扩展或以其他方式更改 TI 针对 TI 产品发布的适用的担保或担保免责声明。

TI 反对并拒绝您可能提出的任何其他或不同的条款。

邮寄地址：Texas Instruments, Post Office Box 655303, Dallas, Texas 75265

Copyright © 2023，德州仪器 (TI) 公司