

CDx4HCx4316 具有电平转换功能的高速 CMOS 逻辑四路模拟开关

1 特性

- 宽模拟输入电压范围：
 $V_{CC} - V_{EE} : 0V$ 至 $10V$
- 低导通电阻：
 - 45Ω (典型值) : $V_{CC} = 4.5V$
 - 35Ω (典型值) : $V_{CC} = 6V$
 - 30Ω (典型值) : $V_{CC} - V_{EE} = 9V$
- 快速开关和传播延迟时间
- 低关断漏电流
- 内置先断后合开关
- 逻辑电平转换，可启用 $5V$ 逻辑以适应 $\pm 5V$ 模拟信号
- 宽工作温度范围： $-55^{\circ}C$ 至 $125^{\circ}C$
- HC 类型：
 - 工作电压为 $2V$ 至 $10V$
 - 高抗噪性：当 $V_{CC} = 5V$ 时， $N_{IL} = 30\%$ ， $N_{IH} = V_{CC}$ 的 30%
- HCT 类型：
 - 直接 LSTTL 输入逻辑兼容性， $V_{IL} = 0.8V$ (最大值)， $V_{IH} = 2V$ (最小值)
 - CMOS 输入兼容性，在 V_{OL} 、 V_{OH} 下 $I_I \leq 1\mu A$

2 说明

HC4316 和 CD74HCT4316 包含四个独立的数控模拟开关，这些开关采用硅栅 CMOS 技术并借助标准 CMOS 集成电路的低功耗特性来实现与 LSTTL 接近的运行速度。

此外，这些器件还包含逻辑电平转换电路，可通过 $5V$ 逻辑电平实现 $\pm 5V$ 电压之间的模拟信号切换。当公共使能 (E) 为低电平时，每个开关由其所选输入 (S) 上的高电平电压导通。E 为高电平时，将禁用所有开关。数字输入可以在 V_{CC} 和 GND 之间摆动；模拟输入/输出可以在 V_{CC} (作为正限值) 和 V_{EE} (作为负限值) 之间摆动。电压范围如图 13-1 和图 13-2 所示。

器件信息

输入		开关
E	S	导通/关断
L	L	关断
L	H	导通
H	H	关断

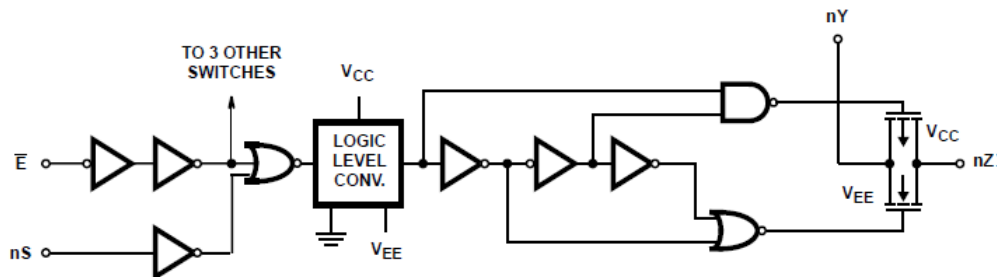

一个开关



Table of Contents

1 特性	1	14 Typical Performance Curves	17
2 说明	1	15 Parameter Measurement Information	18
3 Pin Configurations and Functions	3	16 Detailed Description	20
4 Absolute Maximum Ratings	4	16.1 Functional Block Diagram.....	20
5 Thermal Information	5	16.2 Device Functional Modes.....	20
6 Recommended Operating Conditions	5	17 Device and Documentation Support	21
7 Electrical Characteristics: HC Devices	6	17.1 接收文档更新通知.....	21
8 Electrical Characteristics: HCT Devices	9	17.2 支持资源.....	21
9 Switching Characteristics HC	10	17.3 Trademarks.....	21
10 Switching Characteristics HCT	13	17.4 静电放电警告.....	21
11 Analog Channel Specifications	15	17.5 术语表.....	21
12 HCT Input Loading Table	16	18 Revision History	21
13 Recommended Operating Area as a Function of Supply Voltage	16	19 Mechanical, Packaging, and Orderable Information	21

3 Pin Configurations and Functions



图 3-1. CD74HC4316 (TSSOP)

表 3-1. Pin Functions

PIN		TYPE	DESCRIPTION
NAME	NO.		
1Z	1	I/O	Input/Output for Switch 1
1Y	2	I/O	Input/Output for Switch 1
2Y	3	I/O	Input/Output for Switch 2
2Z	4	I/O	Input/Output for Switch 2
2S	5	I	Control pin for Switch 2
3S	6	I	Control pin for Switch 3
E	7	I	Enable Pin
GND	8	-	Ground Pin
V _{EE}	9	-	Power Pin
3Z	10	I/O	Input/Output for Switch 3
3Y	11	I/O	Input/Output for Switch 3
4Y	12	I/O	Input/Output for Switch 4
4Z	13	I/O	Input/Output for Switch 4
4S	14	I	Control pin for Switch 4
1S	15	I	Control pin for Switch 1
V _{CC}	16	-	Power Pin

4 Absolute Maximum Ratings

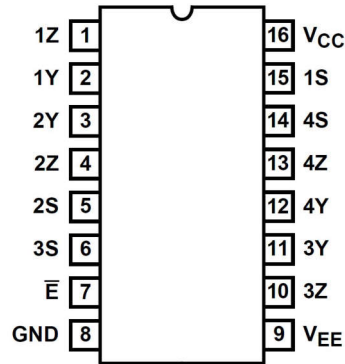
over operating free-air temperature range (unless otherwise noted)⁽¹⁾

			MIN	MAX	UNIT
$V_{CC} - V_{EE}$	DC Supply voltage		-0.5	10.5	V
V_{CC}			- 0.5	7	V
V_{EE}			0.5	-7	V
I_{IK}	DC input diode current	$V_I < - 0.5 \text{ V}$ or $V_I > V_{CC} + 0.5 \text{ V}$	- 20	20	mA
I_{OK}	DC switch diode current	$V_I < V_{EE} - 0.5 \text{ V}$ or $V_I < V_{CC} + 0.5 \text{ V}$	- 25	25	mA
I_{OK}	DC Output Diode Current	For $V_O < -0.5\text{V}$ or $V_O > V_{CC} + 0.5\text{V}$	- 20	20	mA
I_O	DC Output Source or Sink Current per Output Pin	For $V_O > -0.5\text{V}$ or $V_O < V_{CC} + 0.5\text{V}$	- 25	25	mA
I_{CC}	DC V_{CC} or ground current		- 50	50	mA
T_{JMAX}	Maximum junction temperature			150	°C
T_{LMAX}	Maximum lead temperature	Soldering 10 s		300	°C
T_{stg}	Storage temperature		- 65	150	°C

- (1) Stresses beyond those listed under *Absolute Maximum Rating* may cause permanent damage to the device. These are stress ratings only, which do not imply functional operation of the device at these or any other conditions beyond those indicated under *Recommended Operating Condition*. Exposure to absolute-maximum-rated conditions for extended periods may affect device reliability.

5 Thermal Information

THERMAL METRIC ⁽¹⁾		PW (TSSOP)	UNIT
		16 PINS	
$R_{\theta JA}$	Junction-to-ambient thermal resistance	127.9	°C/W

(1) For more information about traditional and new thermal metrics, see the [Semiconductor and IC Package Thermal Metrics](#) application report.

6 Recommended Operating Conditions

over operating free-air temperature range (unless otherwise noted)

			MIN	NOM	MAX	UNIT
V_{CC}	Supply voltage range (T_A = full package temperature range)(2)	CD54 and 74HC types	2		6	V
		CD54 and 74HCT types	4.5		5.5	
$V_{CC} - V_{EE}$ ⁽¹⁾	Supply voltage range (T_A = full package temperature range)(2)	CD54 and 74HC types, CD54 and 74HCT types	2		10	V
V_{EE}	Supply voltage range (T_A = full package temperature range)(3)	CD54 and 74HC types, CD54 and 74HCT types	0		- 6	V
V_I	DC input control voltage		GND		V_{CC}	V
V_{IS}	Analog switch I/O voltage		V_{EE}		V_{CC}	V
T_A	Ambient temperature		- 55		125	°C
t_r, t_f	Input rise and fall times	2 V	0		1000	ns
		4.5 V	0		500	
		6 V	0		400	

(1) V_{DD} and V_{SS} can be any value as long as $3\text{ V} \leq (V_{DD} - V_{SS}) \leq 24\text{ V}$, and the minimum V_{DD} is met.

7 Electrical Characteristics: HC Devices

Over operating free-air temperature range, $V_{SUPPLY} = \pm 5\text{ V}$, and $R_L = 100\ \Omega$, (unless otherwise noted)⁽¹⁾

PARAMETER	TEST CONDITIONS					MIN	TYP	MAX	UNIT	
SIGNAL INPUTS (V_{IS}) AND OUTPUTS (V_{OS})										
	V_{IS} (V)	V_I (V)	V_{EE} (V)	V_{CC} (V)	T_A					
Input High Voltage, V_{IH} , Min				2	25°C			1.5	V	
					- 40°C to +85°C			1.5		
					- 55°C to +125°C			1.5		
					25°C			3.15		
					- 40°C to +85°C			3.15		
					- 55°C to +125°C			3.15		
					6	25°C				4.2
					- 40°C to +85°C			4.2		
					- 55°C to +125°C			4.2		
Input Low Voltage, V_{IL} , Max				2	25°C		0.5		V	
					- 40°C to +85°C		0.5			
					- 55°C to +125°C		0.5			
					4.5	25°C		1.35		
					- 40°C to +85°C		1.35			
					- 55°C to +125°C		1.35			
					6	25°C		1.8		
					- 40°C to +85°C		1.8			
					- 55°C to +125°C		1.8			

Over operating free-air temperature range, $V_{SUPPLY} = \pm 5\text{ V}$, and $R_L = 100\ \Omega$, (unless otherwise noted)⁽¹⁾

PARAMETER	TEST CONDITIONS				MIN	TYP	MAX	UNIT
r_{ON} ON resistance $I_O = 1\text{ mA}$	V_{CC} or V_{EE}	V_{IH} or V_{IL}	0	4.5	25°C	30	180	Ω
					- 40°C to +85°C		225	
					- 55°C to +125°C		270	
			0	6	25°C	35	160	
					- 40°C to +85°C		200	
					- 55°C to +125°C		240	
	V_{CC} to V_{EE}	V_{IH} or V_{IL}	-4.5	4.5	25°C	30	135	Ω
					- 40°C to +85°C		170	
					- 55°C to +125°C		205	
			0	4.5	25°C	40	320	
					- 40°C to +85°C		400	
					- 55°C to +125°C		480	
0	6	25°C	30	240				
		- 40°C to +85°C		300				
		- 55°C to +125°C		360				
-4.5	4.5	25°C	35	170				
		- 40°C to +85°C		215				
		- 55°C to +125°C		255				
Δr_{ON} Maximum ON resistance between any two channels			0	4.5	25°C	10	Ω	
			0	6	25°C	8.5		
			-4.5	4.5	25°C	5		
I_{IZ} Switch OFF leakage current	$V_{CC} - V_{EE}$	V_{IH} or V_{IL} $E = V_{CC}$	0	6	25°C		± 0.1	μA
			0	6	- 55°C to 85°C		± 1	
			0	6	- 55°C to 125°C		± 1	
			-5	5	25°C		± 0.1	
			-5	5	- 55°C to 85°C		± 1	
			-5	5	- 55°C to 125°C		± 1	
I_{IL} Control input leakage current	V_{CC} or GND	0	6	25°C		± 0.1	μA	
				- 55°C to 85°C		± 1		
				- 55°C to 125°C		± 1		

Over operating free-air temperature range, $V_{SUPPLY} = \pm 5\text{ V}$, and $R_L = 100\ \Omega$, (unless otherwise noted)⁽¹⁾

PARAMETER	TEST CONDITIONS				MIN	TYP	MAX	UNIT
Quiescent Device Current, I_{DD} Max $I_O = 1\text{mA}$	When $V_{IS} = V_{EE}$, $V_{OS} = V_{CC}$	V_{CC} or GND	0	6	25°C		14	μA
					- 55°C to 85°C		80	
					- 55°C to 125°C		160	
	When $V_{IS} = V_{CC}$, $V_{OS} = V_{EE}$	V_{CC} or GND	-5	5	25°C		30	
					- 55°C to 85°C		160	
					- 55°C to 125°C		320	
CONTROL (ADDRESS OR INHIBIT), V_C								

(1) For dual-supply systems theoretical worst case ($V_I = 2.4\text{V}$, $V_{CC} = 5.5\text{V}$) specification is 1.8mA

8 Electrical Characteristics: HCT Devices

Over operating free-air temperature range, $V_{SUPPLY} = \pm 5\text{ V}$, and $R_L = 100\ \Omega$, (unless otherwise noted)⁽¹⁾

PARAMETER		TEST CONDITIONS					MIN	TYP	MAX	UNIT
SIGNAL INPUTS (V_{IS}) AND OUTPUTS (V_{OS})										
		V_{IS} (V)	V_I (V)	V_{CC} (V)	V_{EE} (V)	T_A				
High Level Input Voltage	V_{IH}			4.5 to 5.5		25°C	2		V	
						- 40°C to +85°C	2			
						- 55°C to +125°C	2			
Low Level Input Voltage	V_{IL}					25°C		0.8	V	
						- 40°C to +85°C		0.8		
						- 55°C to +125°C		0.8		
"ON" Resistance IO = 1mA	R_{ON}	V_{CC} or V_{EE}	V_{IH} or V_{IL}	4.5	0	25°C		30 180	Ω	
						- 40°C to +85°C		45 225		
						- 55°C to +125°C		270		
		V_{CC} to V_{EE}		4.5	-4.5	25°C		135		
						- 40°C to +85°C		30 170		
						- 55°C to +125°C		205		
	V_{CC} or V_{EE}	4.5	0	25°C		320				
				- 40°C to +85°C		85 400				
				- 55°C to +125°C		480				
	V_{CC} to V_{EE}	4.5	-4.5	25°C		35 170				
				- 40°C to +85°C		215				
				- 55°C to +125°C		255				
"ON" Resistance Between Any Two Switches	$\blacktriangle R_{ON}$		VCC	4.5	0	25°C		10	Ω	
				4.5	-4.5	25°C		5	Ω	
Off-Switch Leakage Current	I_{IZ}	$V_{CC} - V_{EE}$	V_{IH} or V_{IL}	6	0	25°C		± 0.1	μA	
						- 55°C to 85°C		± 1	μA	
						- 55°C to 125°C		± 1	μA	
				5	-5	25°C		± 0.1	μA	
						- 55°C to 85°C		± 1		
						- 55°C to 125°C		± 1		

Over operating free-air temperature range, $V_{SUPPLY} = \pm 5\text{ V}$, and $R_L = 100\ \Omega$, (unless otherwise noted)⁽¹⁾

PARAMETER		TEST CONDITIONS					MIN	TYP	MAX	UNIT
Input Leakage Current (Any Control)	I_{IL}	V_{CC} or GND	5.5	0	25°C			±0.1	μA	
					- 55°C to 85°C			±1		
					- 55°C to 125°C			±1		
Quiescent Device Current	I_{CC}	When $V_{IS} = V_{EE}$, $V_{OS} = V_{CC}$, When $V_{IS} = V_{CC}$, $V_{OS} = V_{EE}$	Any voltage between V_{CC} and GND	5.5	0	25°C			8	μA
						- 55°C to 85°C			80	
						- 55°C to 125°C			160	
				5.5	-4.5	25°C			16	
						- 55°C to 85°C			160	
						- 55°C to 125°C			320	
Additional Quiescent Device Current Per Input Pin: 1 Unit Load	$\Delta I_{CC(1)}$	$V_{CC} - 2.1$	4.5 to 5.5			25°C	100	360	μA	
						- 55°C to 85°C				450
						- 55°C to 125°C				490
CONTROL (ADDRESS OR INHIBIT), V_C										

(1) For dual-supply systems theoretical worst case ($V_I = 2.4\text{V}$, $V_{CC} = 5.5\text{V}$) specification is 1.8mA

9 Switching Characteristics HC

over operating free-air temperature range (unless otherwise noted)

Parameter		VEE (V)	VCC (V)	Test Conditions		MIN	NOM	MAX	UNIT
Propagation Delay, Switch In to Out	t_{PLH} , t_{PHL}	0	2	50pF	25°C			60	ns
			2		- 40°C to +85°C			75	
			2		- 55°C to +125°C			90	
			4.5		25°C			12	
			4.5		- 40°C to +85°C			15	
			4.5		- 55°C to +125°C			18	
			6		25°C			10	
			6		- 40°C to +85°C			13	
			6		- 55°C to +125°C			15	
			4.5		25°C			8	
			4.5		- 40°C to +85°C			10	
			4.5		- 55°C to +125°C			12	

over operating free-air temperature range (unless otherwise noted)

Parameter		VEE (V)	VCC (V)	Test Conditions		MIN	NOM	MAX	UNIT
Turn "ON" Time !E to Out	tPZH, tPZL	0	2	50pF	25°C			205	ns
		0	2		- 40°C to +85°C		255		
		0	2		- 55°C to +125°C		310		
		0	4.5		25°C		41		
		0	4.5		- 40°C to +85°C		51		
		0	4.5		- 55°C to +125°C		62		
		0	6		25°C		35		
		0	6		- 40°C to +85°C		43		
		0	6		- 55°C to +125°C		53		
		-4.5	4.5		25°C		37		
		-4.5	4.5		- 40°C to +85°C		47		
		-4.5	4.5		- 55°C to +125°C		56		
		-	5		15pF	25°C		8	
		Turn "ON" Time nS to Out	tPZH, tPZL	0	2	50pF	25°C		
0	2			- 40°C to +85°C			220		
0	2			- 55°C to +125°C			265		
0	4.5			25°C			35		
0	4.5			- 40°C to +85°C			44		
0	4.5			- 55°C to +125°C			53		
0	6			25°C			30		
0	6			- 40°C to +85°C			37		
0	6			- 55°C to +125°C			45		
-4.5	4.5			25°C			34		
-4.5	4.5			- 40°C to +85°C			43		
-4.5	4.5			- 55°C to +125°C			51		
-	5			15pF	25°C			14	

over operating free-air temperature range (unless otherwise noted)

Parameter		VEE (V)	VCC (V)	Test Conditions		MIN	NOM	MAX	UNIT	
Turn "OFF" Time !E to Out	t_{PLZ}, t_{PHZ}	0	2	50pF	25°C			205	ns	
		0	2		- 40°C to +85°C			255	ns	
		0	2		- 55°C to +125°C			310	ns	
		0	4.5		25°C			41	ns	
		0	4.5		- 40°C to +85°C			51	ns	
		0	4.5		- 55°C to +125°C			62	ns	
		0	6		25°C			35	ns	
		0	6		- 40°C to +85°C			43	ns	
		0	6		- 55°C to +125°C			53	ns	
		-4.5	4.5		25°C			37	ns	
		-4.5	4.5		- 40°C to +85°C			47	ns	
		-4.5	4.5		- 55°C to +125°C			56	ns	
		-	5		15pF	25°C			8	ns
		Turn "OFF" Time nS to Out	t_{PLZ}, t_{PHZ}		0	2	50pF	25°C		
0	2			- 40°C to +85°C				220		
0	2			- 55°C to +125°C				265		
0	4.5			25°C				35		
0	4.5			- 40°C to +85°C				44		
0	4.5			- 55°C to +125°C				53		
0	6			25°C				30		
0	6			- 40°C to +85°C				37		
0	6			- 55°C to +125°C				45		
-4.5	4.5			25°C				34		
-4.5	4.5			- 40°C to +85°C				43		
-4.5	4.5			- 55°C to +125°C				51		
-	5			15pF	25°C				14	

over operating free-air temperature range (unless otherwise noted)

Parameter		VEE (V)	VCC (V)	Test Conditions		MIN	NOM	MAX	UNIT
Input (Control) Capacitance	C _I	-	-	-	25°C			10	pF
Input (Control) Capacitance		-	-		- 40°C to +85°C			10	
Input (Control) Capacitance		-	-		- 55°C to +125°C			10	
Power dissipation capacitance(1)	C _{PD}	-	5		25°C		42		

10 Switching Characteristics HCT

over operating free-air temperature range (unless otherwise noted)

Parameter		VEE (V)	VCC (V)	Test Conditions		MIN	NOM	MAX	UNIT
Propagation Delay, Switch In to Out	t _{PLH} , t _{PHL}	0	4.5	50pF	25°C			12	ns
					- 40°C to +85°C			15	
					- 55°C to +125°C			18	
		25°C				8			
		- 40°C to +85°C				10			
		- 55°C to +125°C				12			
		-4.5	4.5						

over operating free-air temperature range (unless otherwise noted)

Parameter		VEE (V)	VCC (V)	Test Conditions		MIN	NOM	MAX	UNIT
Turn "ON" Time !E to Out	tPZH, tPZL	0	4.5	50pF	25°C			44	ns
					- 40°C to +85°C			55	
					- 55°C to +125°C			66	
					25°C			42	
					- 40°C to +85°C			53	
					- 55°C to +125°C			63	
		-	5	15pF	25°C			18	
		0	4.5	50pF	25°C			56	
					- 40°C to +85°C			70	
					- 55°C to +125°C			85	
					25°C			42	
					- 40°C to +85°C			53	
- 55°C to +125°C						63			
-	5	15pF	25°C			24			
Turn "ON" Time nS to Out	tPZH, tPZL	0	4.5	50pF	25°C			40	ns
					- 40°C to +85°C			53	
					- 55°C to +125°C			60	
					25°C			34	
					- 40°C to +85°C			43	
					- 55°C to +125°C			51	
		0	5	15pF	25°C			17	
		0	4.5	50pF	25°C			50	
					- 40°C to +85°C			63	
					- 55°C to +125°C			75	
					25°C			34	
					- 40°C to +85°C			43	
- 55°C to +125°C						51			
-	5	15pF	25°C			18			

over operating free-air temperature range (unless otherwise noted)

Parameter		VEE (V)	VCC (V)	Test Conditions		MIN	NOM	MAX	UNIT
Turn "OFF" Time t _E to Out	t _{PLZ} , t _{PHZ}	0	4.5	50pF	25°C			50	ns
					- 40°C to +85°C			63	
					- 55°C to +125°C			75	
		-4.5	4.5	50pF	25°C			46	
					- 40°C to +85°C			58	
					- 55°C to +125°C			69	
-	5	15pF	25°C			21			
Turn "OFF" Time t _S to Out	t _{PLZ} , t _{PHZ}	0	4.5	50pF	25°C			44	ns
					- 40°C to +85°C			55	
					- 55°C to +125°C			66	
		-4.5	4.5	50pF	25°C			40	
					- 40°C to +85°C			50	
					- 55°C to +125°C			60	
-	5	15pF	25°C			18			
Input (Control) Capacitance	C _I	-	-	-	25°C			10	pF
		-	-	-	- 40°C to +85°C			10	
		-	-	-	- 55°C to +125°C			10	
Power dissipation capacitance(1)	C _{PD}	-	5	-	25°C			47	

11 Analog Channel Specifications

over operating free-air temperature range (unless otherwise noted)

Parameter	Test Conditions	HC, HCT TYPES	V _{CC} (V)	MIN	NOM	MAX	UNIT
f _{MAX} Minimum switch frequency response at - 3 dB		HC	4.5		200		MHz
		HCT	4.5		200		
THD Sine-wave distortion	1kHz, V _{IS} = 4V _{P-P}	HC	4.5		0.078		%
	1kHz, V _{IS} = 8V _{P-P}		9		0.018		
	1kHz, V _{IS} = 4V _{P-P}	HCT	4.5		0.078		
	1kHz, V _{IS} = 8V _{P-P}		9		0.018		
Switch "OFF" Signal Feedthrough		HC	4.5		-62		dB
		HCT	4.5		-62		

over operating free-air temperature range (unless otherwise noted)

Parameter	Test Conditions	HC, HCT TYPES	V _{CC} (V)	MIN	NOM	MAX	UNIT
Switch Input Capacitance, C _S		HC	-		5		pF
		HCT	-		5		

12 HCT Input Loading Table

INPUT	UNIT LOADS ⁽¹⁾
All	0.5

(1) Unit Load is ΔI_{CC} limit specified in DC Electrical Table, e.g., 360 μ A max at 25°C

13 Recommended Operating Area as a Function of Supply Voltage



图 13-1.



图 13-2.

14 Typical Performance Curves

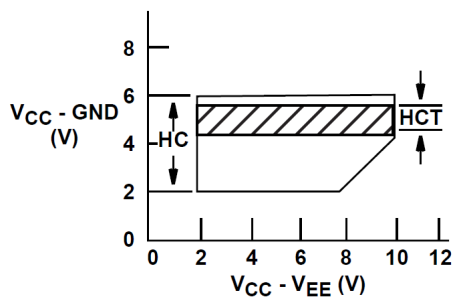

图 14-1. Typical On Resistance vs Input Signal Voltage

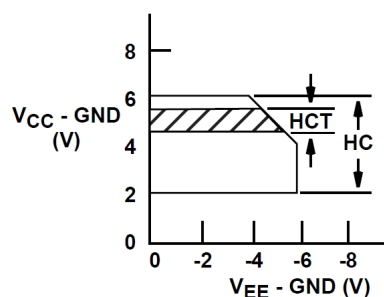

图 14-2. Typical On Resistance vs Input Signal Voltage

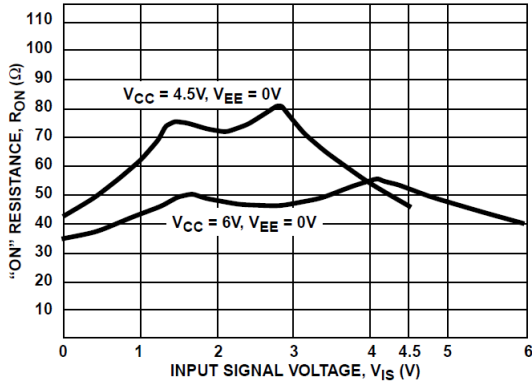

图 14-3. Switch Frequency Response

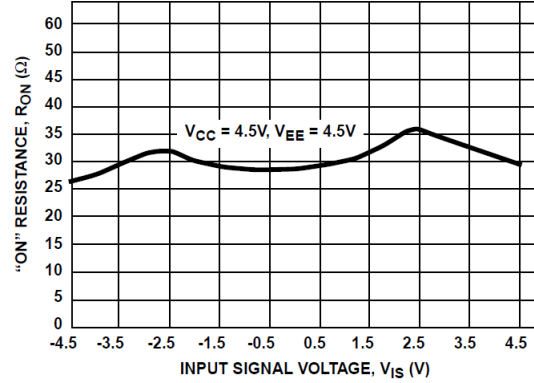

图 14-4. Switch-Off Signal Feedthrough and Crosstalk vs Frequency

15 Parameter Measurement Information

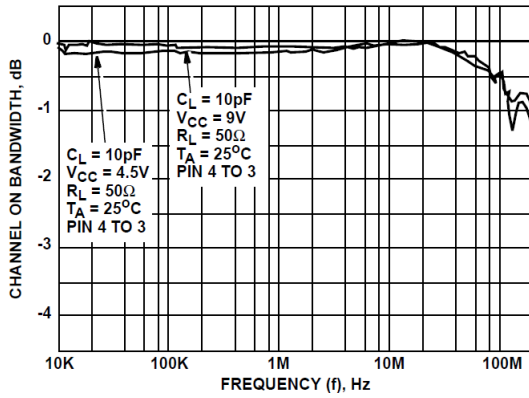

图 15-1. Crosstalk Between Two Switches Test Circuit

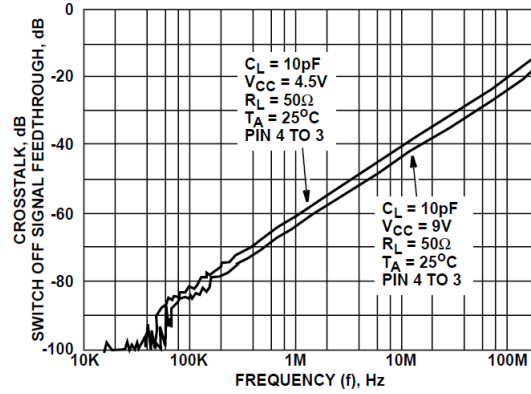

图 15-2. Frequency Response Test Circuit

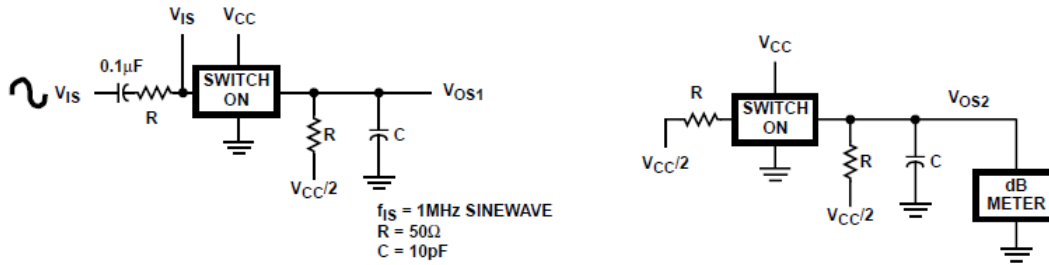

图 15-3. Total Harmonic Distortion Test Circuit

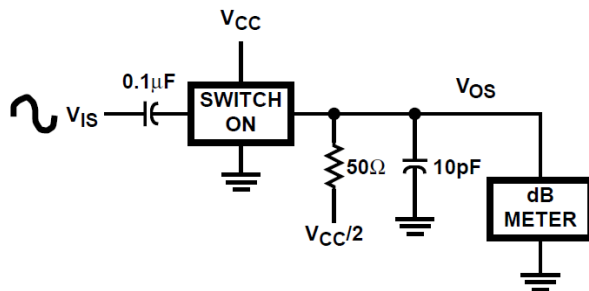

图 15-4. Control-To-Switch Feedthrough Noise Test Circuit

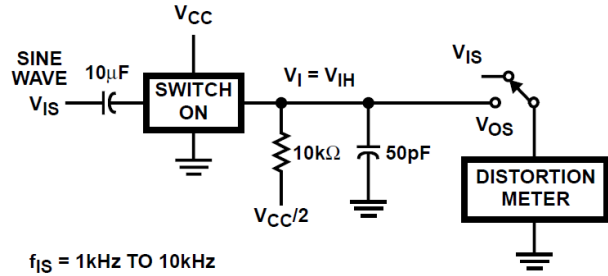

图 15-5. Switch Off Signal Feedthrough Test Circuit

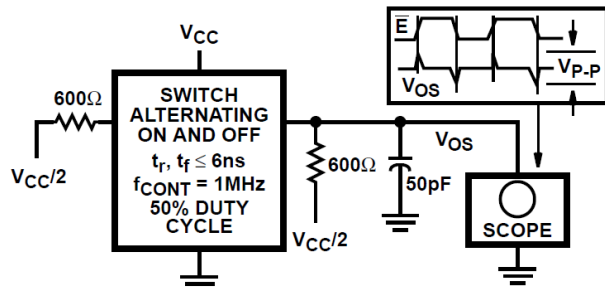

图 15-6. Switch Propagation Delay Times

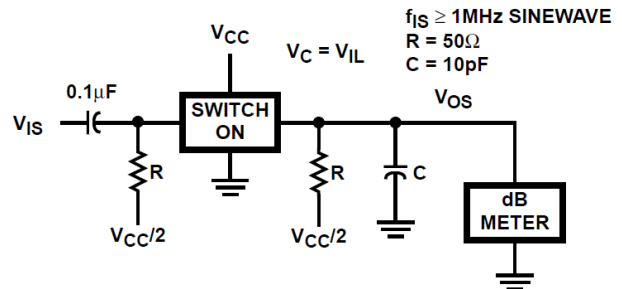

图 15-7. Switch Turn-On and Turn-Off Propagation Delay Times Waveforms

16 Detailed Description

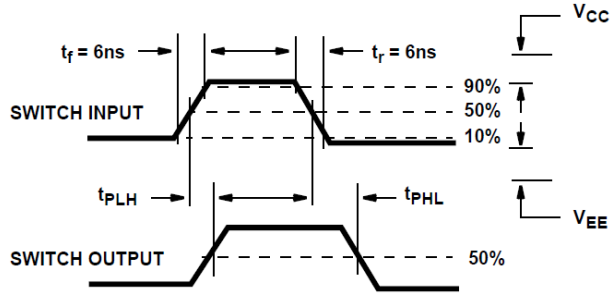
16.1 Functional Block Diagram

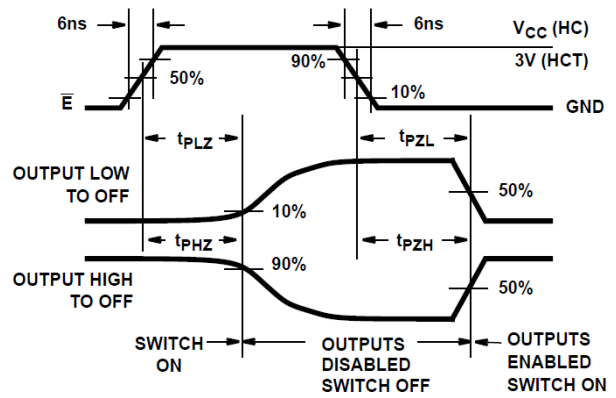
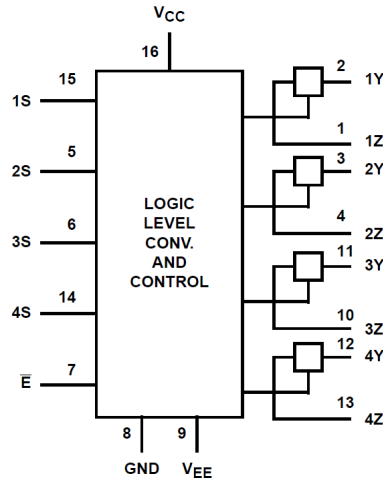

16.2 Device Functional Modes

表 16-1. Truth Table (1)

INPUTS		SWITCH
E	S	
L	L	OFF
L	H	ON
H	X	OFF

(1) H = High Level Voltage, L = Low Level Voltage, X = Do not Care

17 Device and Documentation Support

TI offers an extensive line of development tools. Tools and software to evaluate the performance of the device, generate code, and develop solutions are listed below.

17.1 接收文档更新通知

要接收文档更新通知，请导航至 ti.com 上的器件产品文件夹。点击 [通知](#) 进行注册，即可每周接收产品信息更改摘要。有关更改的详细信息，请查看任何已修订文档中包含的修订历史记录。

17.2 支持资源

TI E2E™ [中文支持论坛](#) 是工程师的重要参考资料，可直接从专家处获得快速、经过验证的解答和设计帮助。搜索现有解答或提出自己的问题，获得所需的快速设计帮助。

链接的内容由各个贡献者“按原样”提供。这些内容并不构成 TI 技术规范，并且不一定反映 TI 的观点；请参阅 TI 的 [使用条款](#)。

17.3 Trademarks

TI E2E™ is a trademark of Texas Instruments.
所有商标均为其各自所有者的财产。

17.4 静电放电警告



静电放电 (ESD) 会损坏这个集成电路。德州仪器 (TI) 建议通过适当的预防措施处理所有集成电路。如果不遵守正确的处理和安装程序，可能会损坏集成电路。

ESD 的损坏小至导致微小的性能降级，大至整个器件故障。精密的集成电路可能更容易受到损坏，这是因为非常细微的参数更改都可能会导致器件与其发布的规格不相符。

17.5 术语表

[TI 术语表](#) 本术语表列出并解释了术语、首字母缩略词和定义。

18 Revision History

注：以前版本的页码可能与当前版本的页码不同

Changes from Revision D (October 2003) to Revision E (July 2024)	Page
• 更新了整个文档中的表格、图和交叉参考的编号格式.....	1
• Updated thermal information.....	5
• Updated electrical specifications.....	6
• Updated switching specifications.....	10
• Updated analog channel specifications.....	15
• Updated orderable information.....	21

19 Mechanical, Packaging, and Orderable Information

The following pages include mechanical, packaging, and orderable information. This information is the most current data available for the designated devices. This data is subject to change without notice and revision of this document. For browser-based versions of this data sheet, refer to the left-hand navigation.

PACKAGING INFORMATION

Orderable Device	Status (1)	Package Type	Package Drawing	Pins	Package Qty	Eco Plan (2)	Lead finish/ Ball material (6)	MSL Peak Temp (3)	Op Temp (°C)	Device Marking (4/5)	Samples
CD54HC4316F3A	ACTIVE	CDIP	J	16	25	Non-RoHS & Green	SNPB	N / A for Pkg Type	-55 to 125	CD54HC4316F3A	Samples
CD74HC4316E	NRND	PDIP	N	16	25	RoHS & Green	NIPDAU	N / A for Pkg Type	-55 to 125	CD74HC4316E	
CD74HC4316M	OBSOLETE	SOIC	D	16		TBD	Call TI	Call TI	-55 to 125	HC4316M	
CD74HC4316M96	ACTIVE	SOIC	D	16	2500	RoHS & Green	NIPDAU	Level-1-260C-UNLIM	-55 to 125	HC4316M	Samples
CD74HC4316NSR	NRND	SO	NS	16	2000	RoHS & Green	NIPDAU	Level-1-260C-UNLIM	-55 to 125	HC4316M	
CD74HC4316PW	OBSOLETE	TSSOP	PW	16		TBD	Call TI	Call TI	-55 to 125	HJ4316	
CD74HC4316PWR	ACTIVE	TSSOP	PW	16	2000	RoHS & Green	NIPDAU	Level-1-260C-UNLIM	-55 to 125	HJ4316	Samples
CD74HCT4316E	NRND	PDIP	N	16	25	RoHS & Green	NIPDAU	N / A for Pkg Type	-55 to 125	CD74HCT4316E	
CD74HCT4316M	NRND	SOIC	D	16	40	RoHS & Green	NIPDAU	Level-1-260C-UNLIM	-55 to 125	HCT4316M	
CD74HCT4316M96	NRND	SOIC	D	16	2500	RoHS & Green	NIPDAU	Level-1-260C-UNLIM	-55 to 125	HCT4316M	

(1) The marketing status values are defined as follows:

ACTIVE: Product device recommended for new designs.

LIFEBUY: TI has announced that the device will be discontinued, and a lifetime-buy period is in effect.

NRND: Not recommended for new designs. Device is in production to support existing customers, but TI does not recommend using this part in a new design.

PREVIEW: Device has been announced but is not in production. Samples may or may not be available.

OBSOLETE: TI has discontinued the production of the device.

(2) **RoHS:** TI defines "RoHS" to mean semiconductor products that are compliant with the current EU RoHS requirements for all 10 RoHS substances, including the requirement that RoHS substance do not exceed 0.1% by weight in homogeneous materials. Where designed to be soldered at high temperatures, "RoHS" products are suitable for use in specified lead-free processes. TI may reference these types of products as "Pb-Free".

RoHS Exempt: TI defines "RoHS Exempt" to mean products that contain lead but are compliant with EU RoHS pursuant to a specific EU RoHS exemption.

Green: TI defines "Green" to mean the content of Chlorine (Cl) and Bromine (Br) based flame retardants meet JS709B low halogen requirements of <=1000ppm threshold. Antimony trioxide based flame retardants must also meet the <=1000ppm threshold requirement.

(3) MSL, Peak Temp. - The Moisture Sensitivity Level rating according to the JEDEC industry standard classifications, and peak solder temperature.

(4) There may be additional marking, which relates to the logo, the lot trace code information, or the environmental category on the device.

(5) Multiple Device Markings will be inside parentheses. Only one Device Marking contained in parentheses and separated by a "~" will appear on a device. If a line is indented then it is a continuation of the previous line and the two combined represent the entire Device Marking for that device.

⁽⁶⁾ Lead finish/Ball material - Orderable Devices may have multiple material finish options. Finish options are separated by a vertical ruled line. Lead finish/Ball material values may wrap to two lines if the finish value exceeds the maximum column width.

Important Information and Disclaimer:The information provided on this page represents TI's knowledge and belief as of the date that it is provided. TI bases its knowledge and belief on information provided by third parties, and makes no representation or warranty as to the accuracy of such information. Efforts are underway to better integrate information from third parties. TI has taken and continues to take reasonable steps to provide representative and accurate information but may not have conducted destructive testing or chemical analysis on incoming materials and chemicals. TI and TI suppliers consider certain information to be proprietary, and thus CAS numbers and other limited information may not be available for release.

In no event shall TI's liability arising out of such information exceed the total purchase price of the TI part(s) at issue in this document sold by TI to Customer on an annual basis.

OTHER QUALIFIED VERSIONS OF CD54HC4316, CD74HC4316 :

- Catalog : [CD74HC4316](#)
- Military : [CD54HC4316](#)

NOTE: Qualified Version Definitions:

- Catalog - TI's standard catalog product
- Military - QML certified for Military and Defense Applications

重要声明和免责声明

TI“按原样”提供技术和可靠性数据（包括数据表）、设计资源（包括参考设计）、应用或其他设计建议、网络工具、安全信息和其他资源，不保证没有瑕疵且不做任何明示或暗示的担保，包括但不限于对适销性、某特定用途方面的适用性或不侵犯任何第三方知识产权的暗示担保。

这些资源可供使用 TI 产品进行设计的熟练开发人员使用。您将自行承担以下全部责任：(1) 针对您的应用选择合适的 TI 产品，(2) 设计、验证并测试您的应用，(3) 确保您的应用满足相应标准以及任何其他功能安全、信息安全、监管或其他要求。

这些资源如有变更，恕不另行通知。TI 授权您仅可将这些资源用于研发本资源所述的 TI 产品的应用。严禁对这些资源进行其他复制或展示。您无权使用任何其他 TI 知识产权或任何第三方知识产权。您应全额赔偿因在这些资源的使用中对 TI 及其代表造成的任何索赔、损害、成本、损失和债务，TI 对此概不负责。

TI 提供的产品受 [TI 的销售条款](#) 或 [ti.com](#) 上其他适用条款/TI 产品随附的其他适用条款的约束。TI 提供这些资源并不会扩展或以其他方式更改 TI 针对 TI 产品发布的适用的担保或担保免责声明。

TI 反对并拒绝您可能提出的任何其他或不同的条款。

邮寄地址：Texas Instruments, Post Office Box 655303, Dallas, Texas 75265

Copyright © 2024，德州仪器 (TI) 公司